



KERN EW 600-C3 NM

Version 1.0 05/2004

Operating Instructions

Carat balance

Table of contents

1	Technical data	36
2	Declaration of conformity	37
3	Fundamental information (general)	39
3.1	Intended use	39
3.2	Inappropriate use	39
3.3	Guarantee	39
3.4	Monitoring the test substances	40
4	Fundamental safety information	40
4.1	Observe the information in the operating instructions	40
4.2	Staff training	40
5	Transport and storage	40
5.1	Acceptance check	40
5.2	Packaging	40
6	Unpacking, installation and commissioning	41
6.1	Place of installation, place of use	41
6.2	Unpacking	41
6.2.1	Installation	42
6.2.2	List of items supplied	42
6.2.3	Positioning the weighing plate	43
6.3	Mains supply	43
6.4	Operation using a rechargeable battery (optional)	43
6.5	Connecting peripheral equipment	45
6.6	Initial start-up	45
6.6.1	Power display	45
6.6.2	Bar graph display	45
6.6.3	Stability indication	46
6.6.4	Zero display on the balance	46
6.7	Adjustment	47
6.8	Adjusting	47
6.9	Verification	49
6.10	Verification switch and official seal	50

7	Operation	51
7.1	Operating elements	51
7.1.1	Overview of the keypad	52
7.1.2	Overview of display	53
7.2	Operation	54
7.2.1	Weighing	54
7.2.2	Tare weighing (tare)	55
8	Functions	57
8.1	Access and changing of numerous functions:	57
8.2	List of the function parameters	58
8.2.1	Parameters for the serial interface	60
9	Data output	61
9.1	Description of the serial data output (RS 232C)	61
9.2	Technical data of the interface	61
9.3	Interface description	62
9.4	Data Output	62
9.4.1	Data Transmission Formats	62
9.4.2	Algebraic sign	63
9.4.3	Data	63
9.4.4	Units	63
9.4.5	Data state	63
10	Maintenance, upkeep, disposal	64
10.1	Cleaning	64
10.2	Maintenance, upkeep	64
10.3	Disposal	64
11	Troubleshooting	65

1 Technical data

KERN	EW 600-C3 NM	
<i>Readout</i>	<i>0,001 ct</i>	<i>0,001 g</i>
<i>Weighing range (max.)</i>	<i>600 ct</i>	<i>120 g</i>
<i>Taring range (subtractive)</i>	<i>600 ct</i>	<i>120 g</i>
<i>Verification value</i>	<i>0,01 ct</i>	<i>0,01 g</i>
<i>Minimum load (Min)</i>	<i>0,1 ct</i>	<i>0,02 g</i>
<i>Reproducibility</i>	<i>0,003 ct</i>	
<i>Linearity</i>	<i>± 0,003 ct</i>	
<i>Test weight (included)</i>	<i>50 g (F2)</i>	
<i>Stabilization time</i>	<i>3 sec.</i>	
<i>Weighing plate stainless steel</i>	<i>Ø 80 mm</i>	
<i>Weight kg (net)</i>	<i>1,6</i>	
<i>Units, verification switch in verification position(chap. 6.10)</i>	<i>g, ct,</i>	
<i>Units , verification switch not in verification position (chap. 6.10)</i>	<i>g, ct, oz, lb, ozt, dwt, GN, tl (HongKong), tl (Taiwan), tl (Singapore, Malaysia), momme, tola</i>	
<i>Air humidity</i>	<i>max. 80 % relative (not condensing)</i>	
<i>Permissible ambient condition</i>	<i>10° C to 30° C</i>	
<i>Balance dimensions</i>	<i>185 x 235 x 165 mm (including draft shield)</i>	
<i>Vibratory filter</i>	<i>4</i>	
<i>Mains supply</i>	<i>Mains adaptor 230 V, 50/60 Hz ; 9 V DC balance, 200 mA</i>	
<i>Interface</i>	<i>RS 232 C interfaced</i>	
<i>Rechargeable battery</i>	<i>optional</i>	

2 Declaration of conformity



KERN & Sohn GmbH
Ziegelei 1
D-72336 Balingen
E-Mail: info@kern-sohn.com

Tel: 0049-[0]7433- 9933-0
Fax: 0049-[0]7433-9933-149
Internet: www.kern-sohn.com

Declaration of conformity

for apparatus with CE mark
Konformitätserklärung für Geräte mit CE-Zeichen
Déclaration de conformité pour appareils portant la marque CE
Declaración de conformidad para aparatos con disitintivo CE
Dichiarazione di conformità per apparecchi contrassegnati con la marcatura CE

- English** We hereby declare that the product to which this declaration refers conforms with the following standards.
- Deutsch** Wir erklären hiermit, dass das Produkt, auf das sich diese Erklärung bezieht, mit den nachstehenden Normen übereinstimmt.
- Français** Nous déclarons avec cela responsabilité que le produit, auquel se rapporte la présente déclaration, est conforme aux normes citées ci-après.
- Español** Manifestamos en la presente que el producto al que se refiere esta declaración est´a de acuerdo con las normas siguientes
- Italiano** Dichiariamo con ciò che il prodotto al quale la presente dichiarazione si riferisce è conforme alle norme di seguito citate.

Balance lines: EW 600-C3 NM

Mark applied	EU Directive	Standards
	89/336EEC EMC	EN45501 EN55022

Date: 01.05.2004

Signature:

Gottl. KERN & Sohn GmbH
Management

Gottl. KERN & Sohn GmbH, Ziegelei 1, D-72336 Balingen, Tel. +49-07433/9933-0, Fax +49-074433/9933-149



KERN & Sohn GmbH
 Ziegelei 1
 D-72336 Balingen
 E-Mail: info@kern-
 sohn.com

Tel: 0049-[0]7433- 9933-0
 Fax: 0049-[0]7433-9933-149
 Internet: www.kern-
 sohn.com

Declaration of conformity

Declaration of conformity for apparatus with CE mark
Konformitätserklärung für Geräte mit CE-Zeichen
Déclaration de conformité pour appareils portant la marque CE
Declaración de conformidad para aparatos con disitintivo CE
Dichiarazione di conformità per apparecchi contrassegnati con la marcatura CE

- English** We hereby declare that the product to which this declaration refers conforms with the following standards.
This declaration is only valid with the certificate of conformity by a notified body.
- Deutsch** Wir erklären hiermit, dass das Produkt, auf das sich diese Erklärung bezieht, mit den nachstehenden Normen übereinstimmt.
Diese Erklärung gilt nur in Verbindung mit der Konformitätsbescheinigung einer benannten Stelle.
- Français** Nous déclarons avec cela responsabilité que le produit, auquel se rapporte la présente déclaration, est conforme aux normes citées ci-après.
Cette déclaration est valide seulement avec un certificat de conformité d'un organisme notifié.
- Español** Manifestamos en la presente que el producto al que se refiere esta declaración est´a de acuerdo con las normas siguientes.
Esta declaración solo será válida acompañada del certificado de conformidad de conformidad de la parte nominal.
- Italiano** Dichiariamo con ciò che il prodotto al quale la presente dichiarazione si riferisce è conforme alle norme di seguito citate.
Questa dichiarazione sarà valida solo se accompagnata dal certificato di conformità della parte nominale.

Model:	EW 600-C3 NM
---------------	---------------------

EU Directive	Standards	EC-type-approval certificate no.	Issued by
90/384/EEC	EN45501	T6451	NMI

Date: 01.05.2004

Signature:

Gottl. KERN & Sohn GmbH
 Management

Gottl. KERN & Sohn GmbH, Ziegelei 1, D-72336 Balingen, Tel. +49-07433/9933-0, Fax +49-074433/9933-149

3 Fundamental information (general)

3.1 Intended use

The balance you have acquired serves to determine the weighing value of the material to be weighed. It is intended to be used as a “non-automatic” balance, i.e. the material to be weighed is manually and carefully placed in the centre of the weighing plate. The weighing value can be read off after a stable weighing value has been obtained.

3.2 Inappropriate use

Do not use the balance for dynamic weighing. In the event that small quantities are removed or added to the material to be weighed, incorrect weighing results can be displayed due to the “stability compensation” in the balance. (Example: Slowly draining fluids from a container on the balance.)

Do not leave a permanent load on the weighing plate. This can damage the measuring equipment.

Be sure to avoid impact shock and overloading the balance in excess of the prescribed maximum load rating (max.), minus any possible tare weight that is already present. This could cause damage to the balance.

Never operate the balance in hazardous locations. The series design is not explosion-proof.

Structural alterations may not be made to the balance. This can lead to incorrect weighing results, faults concerning safety regulations as well as to destruction of the balance.

The balance may only be used in compliance with the described guidelines. Varying areas of application/planned use must be approved by KERN in writing.

3.3 Guarantee

The guarantee is not valid following

- non-observation of our guidelines in the operating instructions
- use outside the described applications
- alteration to or opening of the device
- mechanical damage and damage caused by media, liquids
- natural wear and tear
- inappropriate erection or electric installation
- overloading of the measuring equipment

3.4 Monitoring the test substances

The metrology features of the balance and any possible available adjusting weight must be checked at regular intervals within the scope of quality assurance. For this purpose, the answerable user must define a suitable interval as well as the nature and scope of this check. Information is available on KERN's home page (www.kern-sohn.com) with regard to the monitoring of balance test substances and the test weights required for this. Test weights and balances can be adjusted quickly and at a reasonable price in KERN's accredited DKD calibration laboratory (return to national normal).

4 Fundamental safety information

4.1 Observe the information in the operating instructions

Please read the operating instructions carefully before erecting and commissioning, even if you already have experience with KERN balances.

4.2 Staff training

The device may only be operated and looked after by trained members of staff.

5 Transport and storage

5.1 Acceptance check

Please check the packaging immediately upon delivery and the device during unpacking for any visible signs of external damage.

5.2 Packaging

Please retain all parts of the original packaging in case it should be necessary to return items at any time.

Only the original packaging should be used for return consignments.

Before despatch, disconnect all attached cables and loose/movable parts.

Apply any intended transport security devices. Secure all parts, e.g. glass windshield, weighing plate, power unit etc., to prevent slipping and damage.

6 Unpacking, installation and commissioning

6.1 Place of installation, place of use

The balance is constructed in such a way that reliable weighing results can be achieved under normal application conditions.

By selecting the correct location for your balance, you will be able to work quickly and precisely.

Therefore please observe the following at the place of installation:

- Place the balance on a firm, level surface;
- Avoid extreme heat as well as temperature fluctuation caused by installing next to a radiator or in the direct sunlight;
- Protect the balance against direct draughts due to open windows and doors;
- Avoid jarring during weighing;
- Protect the balance against high humidity, vapours and dust;
- Do not expose the device to extreme dampness for longer periods of time. Inadmissible bedewing (condensation of air moisture on the device) can occur if a cold device is taken into a significantly warmer environment. In this case, please acclimatise the device for approx. 2 hours at room temperature after it has been disconnected from the mains.
- Avoid static charging of the material to be weighed, weighing container and windshield.

Major display deviations (incorrect weighing results) are possible if electromagnetic fields occur as well as due to static charging and instable power supply. It is then necessary to change the location.

6.2 Unpacking

Carefully remove the balance from its packaging, remove the plastic wrapping and position the balance in its intended working location.

6.2.1 Installation

Use the foot screws to level the balance until the air bubble in the bubble level is in the prescribed circle.

6.2.2 List of items supplied

Standard accessories:

(1) Balance

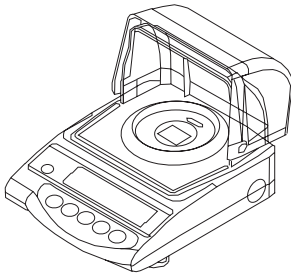

(2) Weighing plate

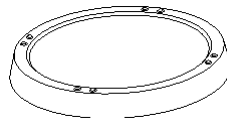

(3) Weighing plate bracket

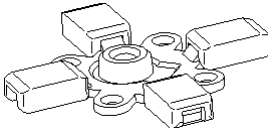

(4) Mains Adapter

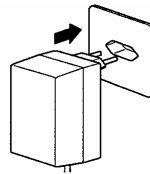

(5) Interface connector set

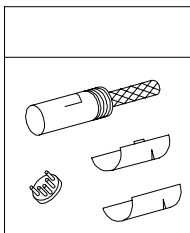

(6) Operating instructions

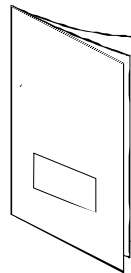

6.2.3 Positioning the weighing plate

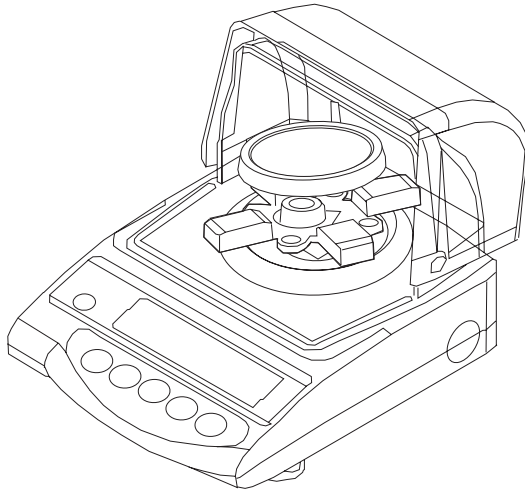

Screw the bracket on tightly according to the drawing and subsequently attach the weighing plate.

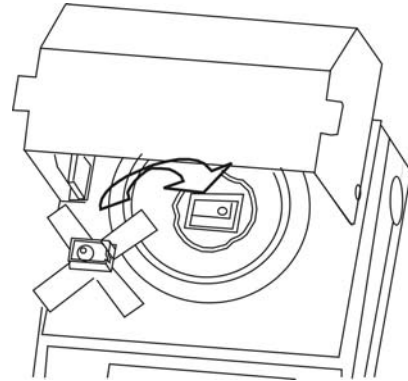

6.3 Mains supply

Electric power supply is by means of the external mains supply circuit. The printed voltage level must comply with the local voltage.

Only use original KERN mains supply circuits. The use of other makes is subject to approval by KERN.

Mains adaptor connection:

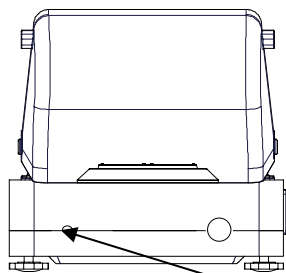

Mains adaptor connection

6.4 Operation using a rechargeable battery (optional)

Take off the weighing plate and remove the bracket by loosening the screw. Use a screwdriver to loosen both screws to the left and right of the bracket guide and remove.

How to remove the draft shield:

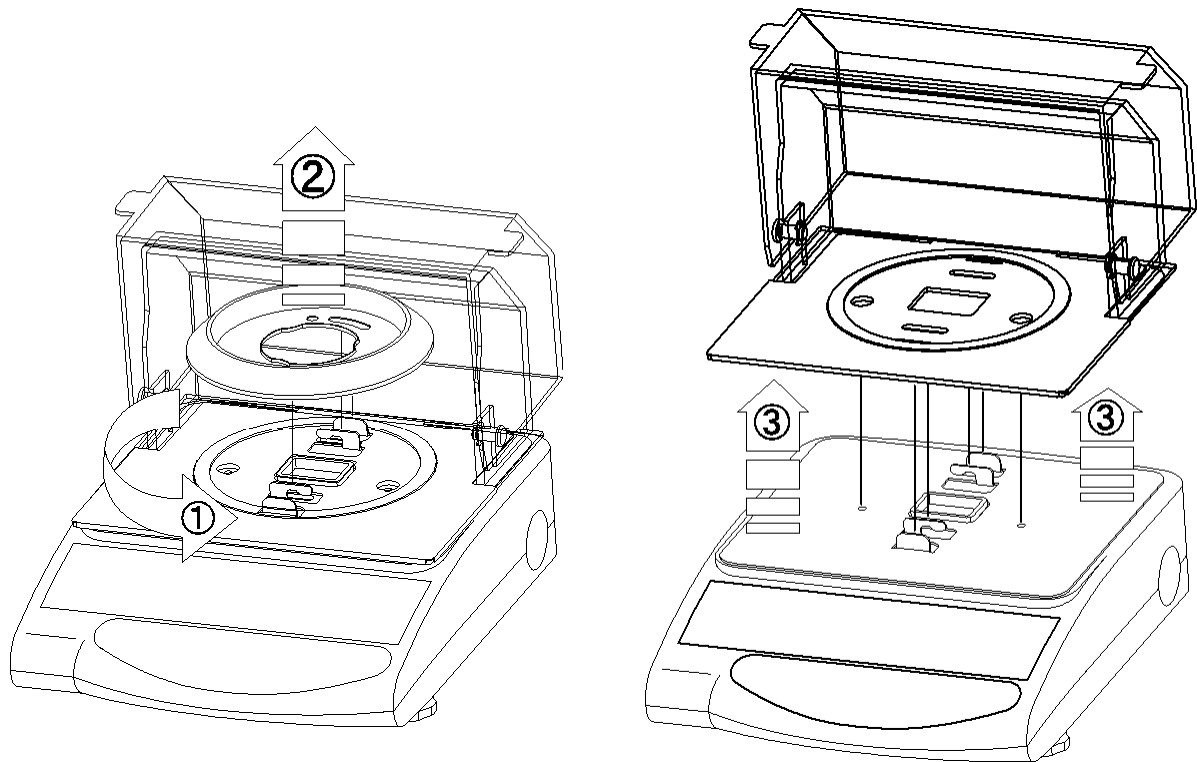

Release both retaining hooks on the lower housing section and carefully remove the lower housing section to the rear (please observe the upper housing section guides on the back of the balance).

Loosen and remove both fastening screws as shown on the illustration (Akkupac).

Remove the rechargeable battery from the packaging and **begin by connecting the electric power supply to the circuit board of the rechargeable battery.**

Subsequently set up the plug-in connection to the computer circuit board of the balance (CN5).

The rechargeable battery is placed on the left side of the housing in such a way that it can be screwed onto the balance through the existing mounting using the screw loosened previously. Press lightly into the housing prior to this, (there is only one correct installation possibility). Now also re-attach the display using the loosened screw.

Place the upper housing section on the rear guides and tilt forward until both retaining hooks on the lower housing section audibly lock into place.

Screw down both screws to the left and right of the bracket guide tightly and re-secure the bracket. Attach the weighing plate.

Information:

Though the rechargeable battery is immediately operative, it should be charged for at least 8 hours using the mains adaptor before being used for the first time.

6.5 Connecting peripheral equipment

The balance must be disconnected from the mains before connecting or disconnecting additional equipment (printer, PC) to or from the data interface (see **chap. 9.**)

Only use KERN accessories and peripheral equipment with your balance. These have been ideally coordinated to your balance.

6.6 Initial start-up

A warm-up time of 10 minutes stabilises the measured values after switching on.

The accuracy of the balance depends on the local acceleration of the fall.

Please be sure to observe the information in the chapter on adjusting (**chap. 6.7.**)

6.6.1 Power display

If the (*) sign can be seen, the balance is being supplied with power via the mains adaptor. The balance is in weighing mode when the  key is operated.

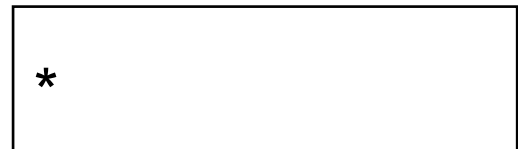

The power display is then no longer to be seen on the display overview.

6.6.2 Bar graph display

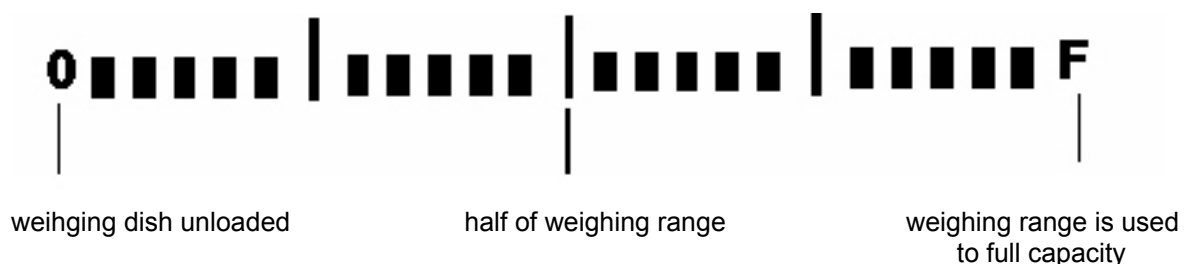

The weighing range of the balance is divided into 20 graphic cuboids. Zero (0) will appear on the graphic display if there is no weighing value on the balance. 10 graphic cuboids are displayed if the balance is loaded up to one half of its weighing range.

Information:

If tare weighing is being carried out, the graphic weight display will continue to indicate the number of cuboids of the tare weight.

6.6.3 Stability indication



Stable





Unstable

The balance is in a stable condition if the [o] stability indication appears on the display. The [o] indication disappears if the condition is unstable.

6.6.4 Zero display on the balance

Environmental influences can lead to the exact figure of “**0.000**” not being displayed in spite of an empty weighing dish. It is, however, possible to reset your balance to zero at any time and thus ensure that weighing really does commence at zero. Setting to zero when a weight is applied is only possible within a certain type-dependent range. In the event that the balance cannot be reset to zero with an applied weight, this range has been exceeded.

[o - Err] will appear on the display.

Operation	Display
If an exact zero reading is not displayed on the balance in spite of the weighing dish being empty, press the  key and the balance will start resetting to zero.	
Your balance will be set to zero after a short standby time. In addition to this, the sign for the balance zero setting will be displayed [→0←].	

6.7 Adjustment

As the acceleration value due to gravity is not the same at every location on earth, each balance must be coordinated – in compliance with the underlying physical weighing principle - to the existing acceleration due to gravity at its place of location (only if the balance has not already been adjusted to the location in the factory). This adjustment process must be carried out during the initial start-up, after change in location and variation of surrounding temperature. It is also recommendable to adjust the balance periodically during weighing operation in order to obtain exact measured values.

6.8 Adjusting

The adjustment with the provided test weight is possible, however this is not optimally.

We recommend:

Accomplish the adjustment if possible as close as it can at the maximum load of the balance.









You find Information about adjusting weights on Internet homepage :

<http://www.kern-sohn.com>

Adjustment procedure:

Check that the surrounding conditions are stable.

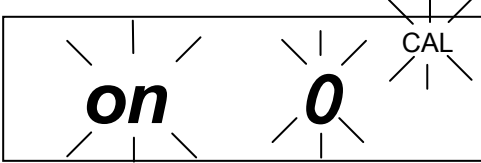
A short warm-up time of about 10 minutes is recommended for stabilisation.

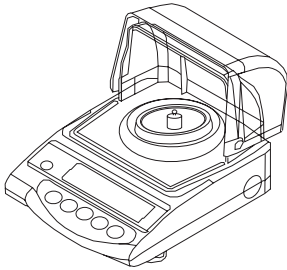
Operation	Display
Switch on the balance using the  key. Close draft shield.	
Press and hold the  key until [CAL] appears. Now release the key.	 <p style="text-align: center;">↓</p> 
Briefly press the  key and the  key. Subsequently release both keys simultaneously. <p style="text-align: center;">↓</p> The zero point will be stored.	 <p style="text-align: center;">↓</p> 
Open draft shield. Place the adjusting weight carefully on the centre of the weighing plate. 	

<p>Close draft shield.</p> <p>Display flashing [on F.S] then a moment later the weight value of the adjusting weight will be indicated.</p> <p>Remove the adjusting weight, the adjusting is terminated.</p> <p>The balance will automatically return to weighing mode.</p> <p>In case of an adjusting error or a wrong adjusting weight [- Err] appears in the display, repeat the adjustment procedure.</p>	<p>The diagram illustrates the sequence of display messages during the adjustment process. It consists of three vertically stacked rectangular boxes, each representing a display state. The first box shows the text 'on' followed by 'F.S' in a larger font, with 'CAL' in the top right corner. The text is surrounded by diagonal lines indicating flashing. A downward arrow points to the second box, which shows 'buSY' in a large font, with 'CAL' in the top right corner. Another downward arrow points to the third box, which shows the weight value '50.000 g' in a large font.</p>
--	--

6.9 Verification

General:

According to the EU guideline 90/384/EEC balances must be verified officially if they are to be used as follows (legally regulated area):

- a) For commercial transactions if the price of goods is determined by weighing
- b) For the production of medicines in pharmacies as well as for analyses in the medical and pharmaceutical laboratory
- c) For official purposes
- d) For the production of finished packages

In case of doubt, please contact your local office of weights and measures.

Verification information

An EU qualification approval is available for those balances marked as appropriate for verification in the technical data. In the event that the balance is applied in an area subject to verification as described above, it must be officially verified and re-verified at regular intervals.

Re-verification of a balance is carried out in compliance with the respective legal provisions of the states. The term of verification validity for balances in Germany, for example, is normally 2 years.

The legal provisions of the country of use are to be observed.

6.10 Verification switch and official seal

Prior to verification the verification switch must be moved from the displayed position (see direction of arrow) to verification position. Once in this position, a parenthesis will be displayed around the last display point. Make sure that only the factory setting **[g]** and **[ct]** for the unit change is selected (chap.8.2)

Following calibration the balance is sealed at the marked position.
Balance calibration is not valid without the “official seals”.

Position of the “official seals”:

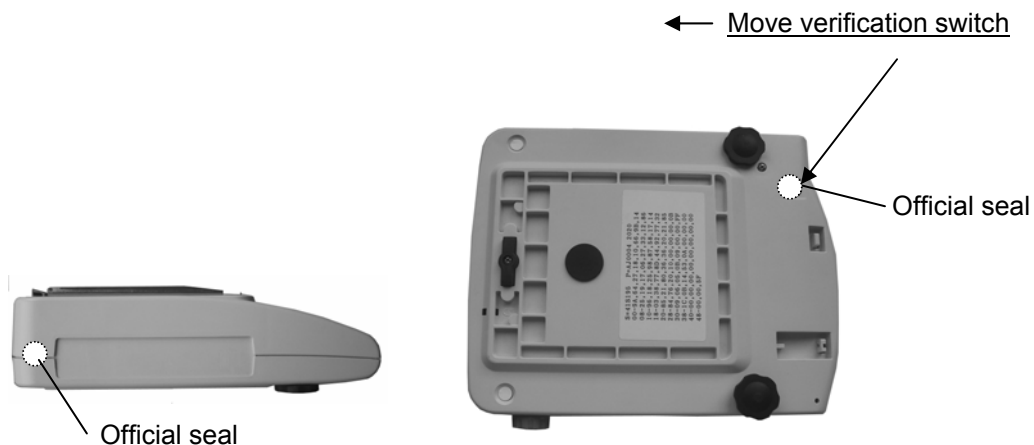

Balances that are subject to compulsory verification must be taken out of operation if:

- The **weighing result** of the balance is outside the **error limit**. Therefore, apply a known test weight (approx. 1/3 of the nominal load) to the balance at regular intervals and compare with the display value.
- The **reverification deadline** has been exceeded.

7 Operation

7.1 Operating elements



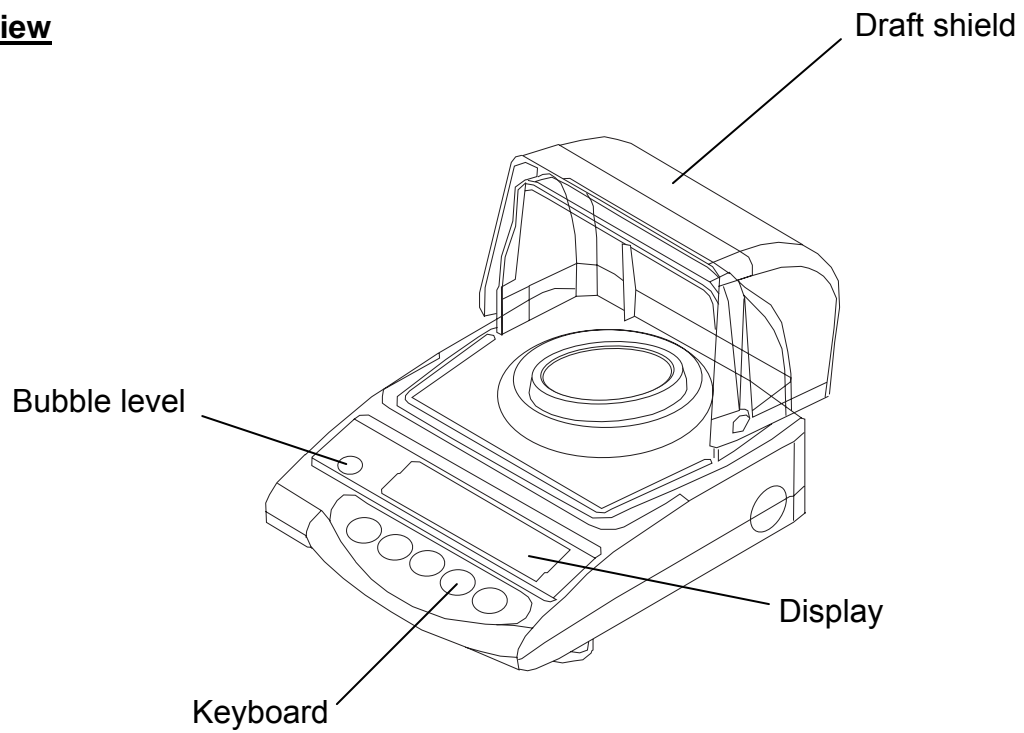

Front view

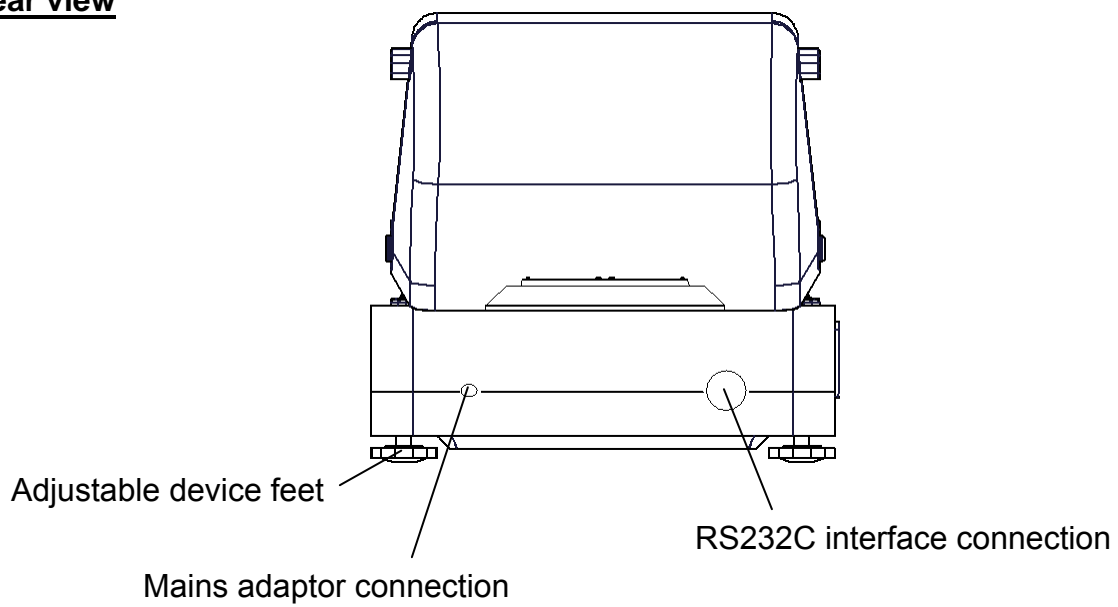

Rear view



7.1.1 Overview of the keypad

Choice	Function
	<ul style="list-style-type: none">• Switch on and off
	<ul style="list-style-type: none">• Output of weight value on an external device (printer) or PC
	<ul style="list-style-type: none">• Save function parameters
	<ul style="list-style-type: none">• Key to alter the weight unit (g, ct)• Choosing the function values within the function• Call up individual functions (multiple print)• Call up adjusting functions (permanent print)
	<ul style="list-style-type: none">• Tare or set weight display to zero• Individual setting within the individual function

7.1.2 Overview of display











Display	Description
ct	(ct) carat
g	(g) gram
oz	(oz) ounce ※1
lb	(lb) pound ※1
oz t	(ozt) fine ounce ※1
dwt	(dwt) penny weight ※1
▶ (lower right)	▶ (lower right) grain ※1
t	(t) Tael (Hong Kong)※1
t (▶ (upper right))	(t ▶ (upper right)) Tael(Singapore, Malaysia) ※1
t (▶ (lower right))	(t ▶ (lower right)) Tael(Taiwan) ※1
mom	(mom) momme
to	(to) Tola ※1
→0←	Zero setting display
NET	Tara being subtracted
o	Stability indication
*	Power display (standby)
M	Balance carry out balance function
CAL	Calibration display. Signalises calibration procedure.
	Bar graph
	Rechargeable battery mode (optional). [] Display changes to mains-powered mode if the voltage falls below the prescribed minimum..

※1 = Verification switch not in verification position







7.2 Operation

7.2.1 Weighing

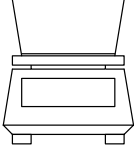

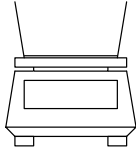
Operation	Display
Press the  key to switch on the balance. The balance will carry out a self-test.	
Your balance is ready to weigh as soon as the "0.000" display appears. Apply the item to be weighed. The weight value is displayed.	 
A switch can be made from one unit to another, e.g. from "g" to another unit, for example "ct", by repeatedly pressing the  key. Setting – see chapter 8 on "Functions". [g] → [ct] → [g] →..... Press the  key to switch the balance off.	  

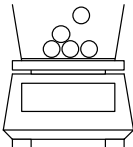
7.2.2 Tare weighing (tare)

The empty weight of any weighing container can be tared at the push of a button, so that the net weight of the item to be weighed is displayed during subsequent weighings.

Operation	Display
<p>Place the empty tare container on the weighing plate. The total weight of the applied container is displayed.</p> 	
<p>Press the  key to start the tare procedure.</p>  <p>The weight of the container is now stored internally.</p>	
<p>Place the items to be weighed in the tare container.</p>  <p>Now read off the weight of the items on the display.</p>	

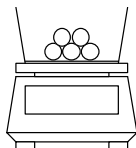
The tare procedure can be repeated as often as desired, for example when weighing several components into a mixture (weighing in).

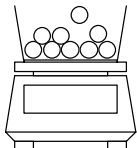
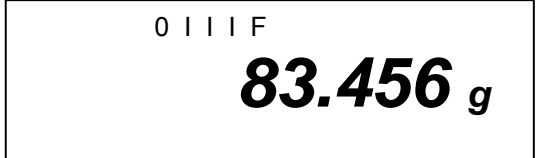
<p>Press the  key to set the display to "0.000".</p>  <p>The total weight of the container is removed by taring.</p>	
<p>Apply further components to the weighing container (weighing in).</p>  <p>Now read off the weight of the added item to be weighed on the display.</p>	

Information:

The balance is only ever able to store one tare value.

The stored tare value is displayed prefixed by a minus sign when the balance is empty.

Remove all items from the weighing plate in order to delete the stored tare value and subsequently press the  key.

The tare procedure can be repeated as often as desired. The limit has been reached when the entire weighing range is used to full capacity.

8 Functions

8.1 Access and changing of numerous functions:



The balance has been set to a certain standard configuration in the factory. This configuration is marked by a ☆.

The configuration can be changed as follows:

Operation	Display
<p>1. Access to the functions.</p> <p>Switch on the balance:</p> <p style="text-align: center;">↓</p> <p>Press the [F] key for about 4 seconds until [FUNC] appears:</p> <p style="text-align: center;">↓</p> <p>When released the following will appear : (possible configurations are listed in chap. 8.2.1).</p> <p style="text-align: center;">↓</p> <p>2. Changing the functions</p> <p>Run through the various functions for configuration by continuing to press the [F] key.</p> <p style="text-align: center;">↓</p> <p>Operate the [TARE] key in order to change the last position in the parameter.</p> <p style="text-align: center;">↓</p> <p>Store the chosen function by operating the [S] key.</p> <p>You will now leave the function menu and return to weighing mode.</p>	<div style="border: 1px solid black; padding: 5px; text-align: center;"> <p>o 0 I I I F</p> <p>0.000 g</p> </div> <p style="text-align: center;">↓</p> <div style="border: 1px solid black; padding: 5px; text-align: center;"> <p>Func</p> </div> <p style="text-align: center;">↓</p> <div style="border: 1px solid black; padding: 5px; text-align: center;"> <p>1 b.G. 1</p> </div> <p style="text-align: center;">↓</p> <div style="border: 1px solid black; padding: 5px; text-align: center;"> <p>3. A0 1</p> </div> <p style="text-align: center;">↓</p> <div style="border: 1px solid black; padding: 5px; text-align: center;"> <p>3. A0 0</p> </div> <p style="text-align: center;">↓</p> <div style="border: 1px solid black; padding: 5px; text-align: center;"> <p>o 0 I I I F</p> <p>0.000 g</p> </div>



8.2 List of the function parameters

The balance has been set to a certain standard configuration in the factory. This is marked by a ☆.

Function	Display		Choice	Description of the choice possibilities
				
Bar graph	1	b.G	0	Off
			☆1	On
Zero alignment	3	A.0	0	No zero point correction
			☆1	Automatic zero point correction activated.
Automatic shutoff for rechargeable battery operation (function is only available in rechargeable battery mode)	4	A.P.	0	Automatic shutoff deactivated for rechargeable battery operation (optional).
			☆1	Automatic shutoff activated for rechargeable battery operation (optional).
Display speed	5	rE.	0	Setting for metering
			1	Sensitive and fast
			2	
		↓	☆3	↓
			4	
			5	Non-sensitive but slow
Vibratory filter	6	S.d.	1	Sensitive and fast (very tranquil installation location).
			☆2	↓
			3	
			4	Non-sensitive but slow (very unsettled installation location).
Interface	7	I.F.	0	Interface not active
			☆1	6-digit data format
			2	7-digit data format (chap. 8.2.1)

Weight unit (only selectable, if the calibration switch is not in the calibration position see Ch. 6.10)	81 ↓ 85	S.u.	1☆01	(g)
			2☆02	(ct)
			15	(oz)
			16	(lb)
			17	(ozt)
			18	(dwt)
			19	(grain)
			1A	(tl Hong Kong)
			1b	(tl Singapore, Malaysia)
			1C	(tl Taiwan)
			1d	(mom)
1E	(to)			
Not documented	9.	Ai	0	Not documented
			☆1	Always use this setting.
Data-out (only selectable, if the calibration switch is not in the calibration position see Ch. 6.10)	A.	PrF.	1	No printout possible, if the last display location is enclosed in brackets.
			2	Printout possible, even if the last display location is enclosed in brackets. Comment: Always select this setting, before the balance is calibrated, as this menu item can no longer be called due to the calibration
			☆3	The printout is only carried out, if the calibration switch is not in the calibration position see Ch. 6.10.

8.2.1 Parameters for the serial interface

Function	Display 	Choice 	Description of the choice possibilities
Output format at interface	7	I.F. ↓	0 Interface not active ☆1 6-digit data format 2 7-digit data format
Output condition at interface (Menu setting "7 I.F. [1] or [2]" only)	71.	o.c. ↓	0 No data issued. 1 Continuous serial output. 2 Continuous serial output upon stabilised display. 3 Output following printing of PRINT. 4 Automatic output upon stable weighing value. The first value to stabilise is adopted if this is -0.00 or less. No new output until weight is removed and a new load applied. 5 Output upon stabilisation, no output if data unstable. 6 Output upon stabilisation, constant output if data unstable. ☆7 Output following printing of PRINT.
Baud rate	72.	b.L.	☆1 1200 bps 2 2400 bps 3 4800 bps 4 9600 bps
Parity (Menu setting "7 I.F. 2" only)	73.	PA.	☆0 No parity bit 1 Uneven parity 2 Even parity

9 Data output

The balance is supplied as standard with an interface RS 232C.

9.1 Description of the serial data output (RS 232C)

The data output is placed at the rear side of the balance. It is a 5-pole standard socket.

Pin description see following illustration

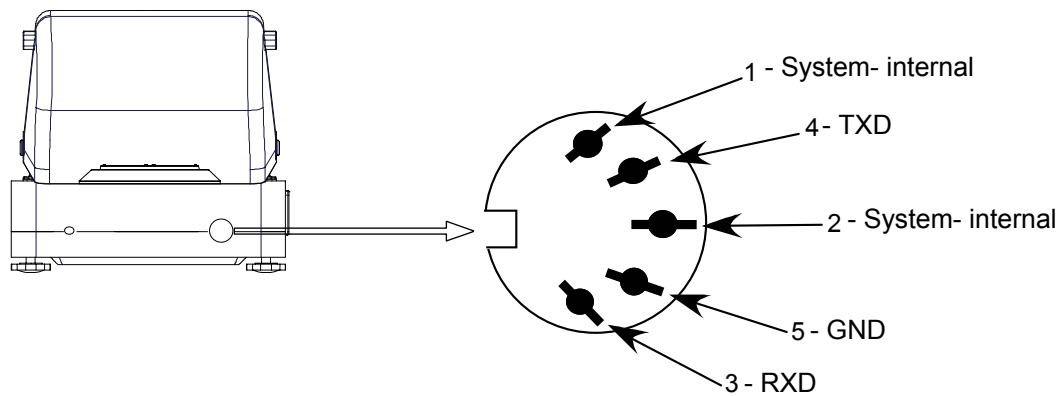

9.2 Technical data of the interface

Transfer format: serial data transfer

Data-bit: 8-bit (standard-ASCII-Format)

Start-bit: 1 bit

Stop-bit: 2 bits

Parity: NON, ODD, EVEN

Baud rate: 1200 / 2400 / 4800 / 9600 baud can be set (see **chap. 8.2.1**)

9.3 Interface description

The output format, output control, transfer speed and parity bit can be set following the choice of a certain operating mode. The various possibilities are described in chap. 8.2.1 "Parameters for the serial interface".

9.4 Data Output

9.4.1 Data Transmission Formats

By selecting the corresponding function at your balance one of the two following data formats can be set:

- **6-digit data format**

Consisting of 14 words including the final signal; CR=0DH, LF=0AH (CR=return travel / LF=line feed)

1	2	3	4	5	6	7	8	9	10	11	12	13	14
P1	D1	D2	D3	D4	D5	D6	D7	U1	U2	S1	S2	CR	LF

- **7-digit data format**

1	2	3	4	5	6	7	8	9	10	11	12	13	14	15
P1	D1	D2	D3	D4	D5	D6	D7	D8	U1	U2	S1	S2	CR	LF

Note: The 7-digit format is identical with the 6-digit format except for the additional signal D8.

9.4.2 Algebraic sign

P 1 = 1 word

P 1	Code	Meaning
+	2 B H	Data are 0 or positive
-	2 D H	Data are negative
sp	20 H	Date are 0 or positive

9.4.3 Data

D 1 to D 7 7 words with 6-digit format

D 1 to D 8 8 words with 7-digit format

D *	Code	Meaning
0 - 9	30 H – 39 H	Data 0 to 9 (max. 6 characters in 6-type format)
. (Point)	2 EH	Decimal point, position not fixed
Sp	20 H	Space character, leading zero oppressed

9.4.4 Units

U 1, U 2 = 2 words as ASCII codes

U1	U2	Code		Meaning	Symbol
(SP)	G	20H	47H	Gram	g
C	T	43H	54H	Carat	c ^t
O	Z	4FH	5AH	Ounze	oz
L	B	4CH	42H	Pound	lb
O	T	4FH	54H	Fine ounce	oz ^t
D	W	44H	57H	Pennyweight	d ^w t
G	R	47H	52H	Grain	▶ (lower right)
T	L	54H	4CH	Tael (Hong Kong)	t ^l
T	L	54H	4CH	Tael (Singapore, Malaysia)	t ^l ▶ (upper right)
T	L	54H	4CH	Tael (Taiwan)	t ^l ▶ (lower right)
M	O	4DH	4FH	Momme	mom
t	o	74H	6FH	Tola	t ^o

9.4.5 Data state

S 2 = 1 Word

S 2	Code	Meaning
S	53 H	Stabilised data *
U	55 H	Data not stabilised (fluctuating) *
E	45 H	Data error, all data unreliable with the exception of S 2. Balance displays error (o-Err, u-Err)
sp	20 H	No special status

10 Maintenance, upkeep, disposal

10.1 Cleaning

Please disconnect the device from the operating voltage before cleaning.

Only use a cloth dampened with mild suds and not aggressive cleaning agents (solvents or similar). Please ensure that fluids are not able to get into the device and rub off using a clean, soft cloth.

Loose sample residue/powder can be removed carefully using a brush or hand vacuum cleaner.

Remove any spilt material to be weighed immediately.

10.2 Maintenance, upkeep

The device may only be opened by trained service engineers authorised by KERN. Disconnect from the mains supply before opening.

10.3 Disposal

The operating company shall dispose of the packaging and the device in compliance with the valid national or regional law of the operating location.

11 Troubleshooting

The balance should be switched off for a short time following an interruption in the programme sequence and disconnected from the mains supply. It is then necessary to repeat the weighing process from the beginning.

Help:

Interruption

Possible cause

Weight display is not illuminated.

- *The balance is not switched on.*
- *The mains supply connection has been interrupted (mains cable not plugged in/faulty).*
- *Power supply interrupted.*

The weight display changes continually

- *Draught/air movement*
- *Table/floor vibrations*
- *The weighing plate is in contact with foreign matter.*
- *Electromagnetic fields / static charging (choose different location/switch off interfering device if possible)*

The weighing result is obviously incorrect

- *The balance display is not set to zero*
- *Adjustment is no longer correct.*
- *Great fluctuations in temperature.*
- *Electromagnetic fields / static charging (choose different location/switch off interfering device if possible)*

Switch the balance off if other error messages should appear and then switch on again. Contact the manufacturer if the error message does not disappear.