

GB

Operating Instructions Electronic crane scale



KERN HTS

Version 1.1 7/2005

HTS-BA-e-0511

71209203

Contents

- 1. TECHNICAL SPECIFICATIONS _____ 3**
 - 1.1 SMALL CONSTRUCTION _____ 3
 - 1.2 LARGE CONSTRUCTION _____ 5
 - 1.3 DIMENSIONS _____ 7
- 2. DECLARATION OF CONFORMITY _____ 10**
- 3. GENERAL SAFETY INSTRUCTIONS _____ 12**
- 4. CRANE SCALE AT A GLANCE _____ 13**
 - 4.1 OVERVIEW _____ 13
 - 4.2 DISPLAY _____ 15
 - 4.3 KEYBOARD _____ 16
 - 4.4 REMOTE CONTROL _____ 17
- 5. COMMISSIONING _____ 18**
 - 5.1 UNPACKING (SMALL CONSTRUCTION) _____ 18
 - 5.2 UNPACKING (LARGE CONSTRUCTION) _____ 18
 - 5.3 RECHARGE THE BATTERY _____ 19
 - 5.4 SUSPEND SCALE _____ 21
- 6. OPERATION _____ 22**
 - 6.1 SAFETY INSTRUCTIONS _____ 22
 - 6.2 LOAD THE CRANE SCALE _____ 22
 - 6.3 TURN ON/OFF _____ 25
 - 6.4 RESET SCALE _____ 25
 - 6.5 TARING _____ 26
 - 6.6 WORKING WITH THE TARE WEIGHTS SAVED _____ 27
 - 6.7 WEIGHING _____ 29
 - 6.8 ACCUMULATION _____ 29
 - 6.9 SHOW PEAK LOAD _____ 32
 - 6.10 STOP WEIGHT VALUE (FREEZE) _____ 32
 - 6.11 BATTERY OPERATION _____ 33
 - 6.12 OPERATION WITH REMOTE CONTROL _____ 34
- 7. USER MENU _____ 35**
 - 7.1 OVERVIEW _____ 35
 - 7.2 ACCESSING USER MENU _____ 35
 - 7.3 OPERATION IN MENU _____ 36
 - 7.4 DESCRIPTION OF THE USER MENU _____ 39
- 8. SERVICE MENU _____ 41**
 - 8.1 OVERVIEW _____ 41
 - 8.2 ACCESS SERVICE MENU _____ 42
 - 8.3 DESCRIPTION OF SERVICE MENU _____ 43
 - 8.4 VERIFICATION _____ 49
- 9. ERROR MESSAGES _____ 51**
- 10. MAINTENANCE & CLEANING _____ 52**
 - 10.1 REGULAR MAINTENANCE _____ 52
 - 10.2 CLEANING _____ 54
 - 10.3 CHANGE THE BATTERIES OF THE REMOTE CONTROL _____ 54
- 11. ENCLOSURE _____ 55**
 - 11.1 TABLE OF GEO VALUES _____ 55

1. Technical specifications

1.1 Small construction

KERN	HTS150K 50IP	HTS300K 100IP	HTS600K 200IP	HTS1.5T 0.5IP
<i>Readability (d)</i>	50 g	100 g	200 g	500 g
<i>Weighing range (Max)</i>	150 kg	300 kg	600 kg	1,500 kg
<i>Taring range (subtractive)</i>	150 kg	300 kg	600 kg	1,500 kg
<i>Reproductability</i>	50 g	100 g	200 g	500g
<i>Linearity</i>	± 100 g	± 200 g	± 400 g	± 1,000g
<i>Verifiable</i>	no	no	no	no
<i>Filters</i>	Selectable: disabled, low, medium or high			
<i>Units</i>	Switchable: lb, kg			
<i>Display</i>	Luminosity, 5 settings, 25mm high numeric LED for weight value 9 LEDs to display the status of the crane scale Luminosity may be adjusted in the user menu			
<i>Housing</i>	IP65 silver painted cast aluminium alloy galvanized hook and shackle			
<i>Power</i>	6V 7Ah rechargeable lead acid battery P65 approx. 300 loading cycles battery charger included: 6.5 V / 0.8			
<i>Operating time</i>	Max. 150 hours between charging			
<i>Working temperature</i>	-10 to +50 °C			
<i>Storage temperature</i>	-30 to +60 °C			
<i>Relative humidity</i>	10 to 95%, non-condensing			
<i>Battery charger</i>	Serially			
<i>Remote control</i>	Serially	<i>Power supply</i>	• 2 AA alkaline batteries	
		<i>Battery change</i>	• After approximately 6 months	

KERN	HTS150K 50IPM	HTS300K 100IPM	HTS600K 200IPM	HTS1.5T 0.5IPM
<i>Readability (d)</i>	50 g	100 g	200 g	500 g
<i>Weighing range (Max)</i>	150 kg	300 kg	600 kg	1,500 kg
<i>Taring range (subtractive)</i>	150 kg	300 kg	600 kg	1,500 kg
<i>Reproductability</i>	50 g	100 g	200 g	500g
<i>Linearity</i>	± 100 g	± 200 g	± 400 g	± 1,000g
<i>Verifiable</i>	yes	yes	yes	yes
<i>Verification value (e)</i>	50 g	100 g	200 g	500 g
<i>Min. charge (Min = 20 d)</i>	1 kg	2 kg	4 kg	10 kg
<i>Accuracy category</i>	III	III	III	III
<i>Filters</i>	Selectable: disabled, low, medium or high			
<i>Units</i>	Switchable: lb, kg			
<i>Display</i>	Luminosity, 5 settings, 25mm high numeric LED for weight value 9 LEDs to display the status of the crane scale Luminosity may be adjusted in the user menu			
<i>Housing</i>	IP65 silver painted cast aluminium alloy galvanized hook and shackle			
<i>Power</i>	6V 7Ah rechargeable lead acid battery P65 approx. 300 loading cycles battery charger included: 6.5 V / 0.8			
<i>Operating time</i>	Max. 150 hours between charging			
<i>Working temperature</i>	-10 to +40 °C			
<i>Storage temperature</i>	-30 to +60 °C			
<i>Relative humidity</i>	10 to 95%, non-condensing			
<i>Battery charger</i>	Serially			
<i>Remote control</i>	Serially	<i>Power supply</i>	• 2 AA alkaline batteries	
		<i>Battery change</i>	• After approximately 6 months	

1.2 Large construction

KERN	HTS3T1IP	HTS6T2IP	HTS10T5IP
<i>Readability (d)</i>	1,000 g	2,000 g	5,000 g
<i>Weighing range (Max)</i>	3,000 kg	6,000 kg	10,000 kg
<i>Taring range (subtractive)</i>	3,000 kg	6,000 kg	7,500 kg
<i>Reproductability</i>	1,000 g	2,000 g	5,000g
<i>Linearity</i>	± 2,000g	± 4,000g	± 10,000 g
<i>Verifiable</i>	no	no	no
<i>Filters</i>	Selectable: disabled, low, medium or high		
<i>Units</i>	Switchable: lb, kg		
<i>Display</i>	Luminosity, 6 settings, 30 mm high numeric LED for weight value bright, 1-digit, 20 mm high numeric LED for the current accumulator number 9 LEDs to display the status of the crane scale Luminosity may be adjusted in the user menu		
<i>Housing</i>	IP65 silver painted cast aluminium alloy galvanized hook and shackle		
<i>Power</i>	6V 7Ah rechargeable lead acid battery P65 approx. 300 loading cycles battery charger included: 6.5 V / 0.8		
<i>Operating time</i>	Max. 150 hours between charging		
<i>Working temperature</i>	-10 to +50 °C		
<i>Storage temperature</i>	-30 to +60 °C		
<i>Relative humidity</i>	10 to 95%, non-condensing		
<i>Battery block</i>	Serially		
<i>Battery charger</i>	Serially		
<i>Remote control</i>	Serially	<i>Power supply</i>	<ul style="list-style-type: none"> • 2 AA alkaline batteries
		<i>Battery change</i>	<ul style="list-style-type: none"> • After approximately 6 months

KERN	HTS3T1IPM	HTS6T2IPM	HTS10T5IPM
Readability (d)	1,000 g	2,000 g	5,000 g
Weighing range (Max)	3,000 kg	6,000 kg	10,000 kg
Taring range (subtractive)	3,000 kg	6,000 kg	7,500 kg
Reproductability	1,000 g	2,000 g	5,000g
Linearity	± 2,000g	± 4,000g	± 10,000 g
Verifiable	yes	yes	yes
Verification value (e)	1,000 g	2,000 g	5,000 g
Min. charge (Min = 20 d)	20 kg	40 kg	100 kg
Accuracy category	III	III	III
Filters	Selectable: disabled, low, medium or high		
Units	Switchable: lb, kg		
Display	Luminosity, 6 settings, 30 mm high numeric LED for weight value bright, 1-digit, 20 mm high numeric LED for the current accumulator number 9 LEDs to display the status of the crane scale Luminosity may be adjusted in the user menu		
Housing	IP65 silver painted cast aluminium alloy galvanized hook and shackle		
Power	6V 7Ah rechargeable lead acid battery P65 approx. 300 loading cycles battery charger included: 6.5 V / 0.8		
Operating time	Max. 150 hours between charging		
Working temperature	-10 to +40 °C		
Storage temperature	-30 to +60 °C		
Relative humidity	10 to 95%, non-condensing		
Battery block	Serially		
Battery charger	Serially		
Remote control	Serially	Power supply	• 2 AA alkaline batteries
		Battery change	• After approximately 6 months

1.3 Dimensions

Small construction:

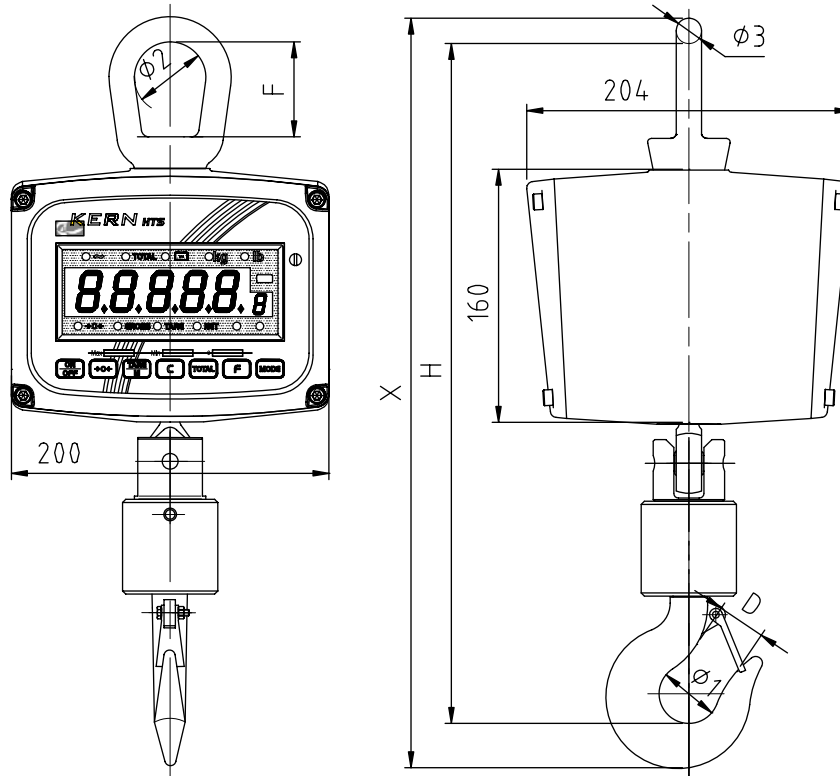

HTS 150kg—600kg

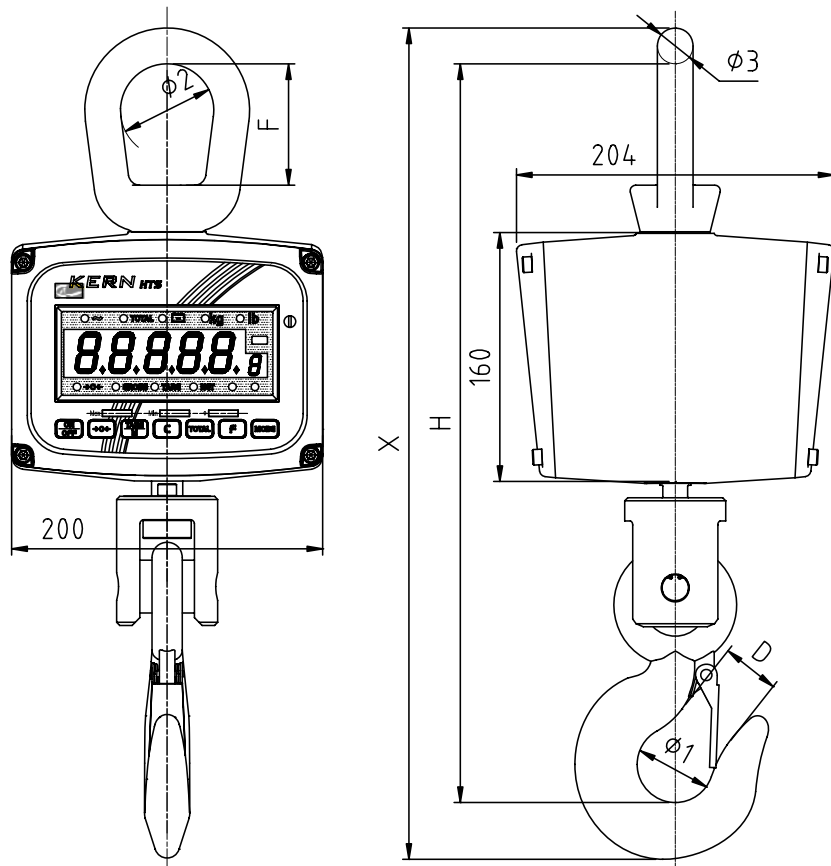

HTS1.5t

Model	Dimension (mm)							Net weight (kg)	Packing	
	D	F	H	Ø1	Ø2	Ø3	X		Gross weight(kg)	L×W×H (mm)
HTS150kg	30	60	435	37.5	45	16	480	11.8	13	530x260x290
HTS300kg										
HTS600kg										
HTS1.5t	28	78	465	40	60	23	516	13.8	15	900x260x390

Large construction:

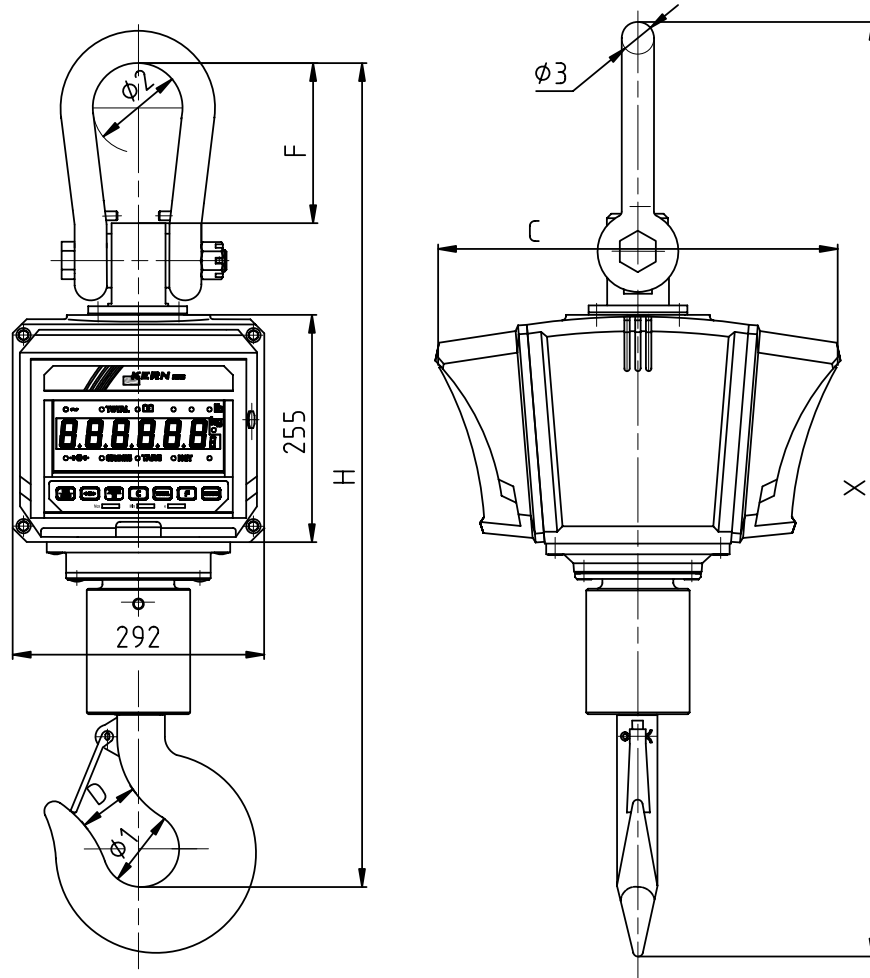

Model	Dimension (mm)								Net weight (kg)	Packing	
	C	D	F	H	Ø1	Ø2	Ø3	X		Gross weight (kg)	L×W×H (mm)
HTS3t	381	46	140	735	61	89	28	815	42	49	900x470x400
HTS6t	419	66	175	899	84	99	36	1040	65	74	1140x530x400
HTS10t											

2. Declaration of conformity



KERN & Sohn GmbH

D-72322 Balingen-Frommern

Post box 4052

E-Mail: info@kern-sohn.de

Tel.: 0049-[0]7433- 9933-0

Fax: 0049-[0]7433-9933-149

Website: www.kern-sohn.de

Declaration of conformity

Declaration of conformity for apparatus with CE mark

Konformitätserklärung für Geräte mit CE-Zeichen

Déclaration de conformité pour appareils portant la marque CE

Declaración de conformidad para aparatos con marca CE

Dichiarazione di conformità per apparecchi contrassegnati con la marcatura CE

English	We hereby declare that the product to which this declaration refers conforms with the following standards.
Deutsch	Wir erklären hiermit, dass das Produkt, auf das sich diese Erklärung bezieht, mit den nachstehenden Normen übereinstimmt.
Français	Nous déclarons avec cela responsabilité que le produit, auquel se rapporte la présente déclaration, est conforme aux normes citées ci-après.
Español	Manifetamos en la presente que el producto al que se refiere esta declaración está de acuerdo con las normas siguientes
Italiano	Dichiariamo con ciò che il prodotto al quale la presente dichiarazione si riferisce è conforme alle norme di seguito citate.

Electronic Crane Scale: KERN HTS

Mark applied	EU Directive	Standards	Approval Test certificat N°
CE	89/336EEC EMC	EN 61326 : 1997+A1+A2	
CE [year] [code] M ¹⁾	90/384/EEC Non automatic weighing Instruments ¹⁾	EN 45501 ¹⁾	T 6778 ¹⁾

¹⁾ applies only to certified balances
gilt nur für geeichte Waagen
valable uniquement pour les balances vérifiées
sóo aplicable a balanzas verificadas
la dichiarazione vale solo per le bilance omologate

Date: 01.03.2005

Signature:

Gottl. KERN & Sohn GmbH
management"

Notice

Certified balances and balances used for legal applications have the EU type approval. The year of the initial verification is shown next to the CE mark. Such balances are verified in the factory and carry the „M“ mark on the actual balance and the packaging. The year of initial verification is shown next to the CE mark. The GEO value of verified balances explains for which location of use the balance has been verified. This GEO value is shown on the balance itself and on the packing. Further details see GEO value table (see chapter 11).

Hinweise

Für geeichte/eichpflichtige Waagen liegt eine EU Bauartzulassung vor. Das Jahr der ersten Eichung ist neben dem CE Zeichen aufgeführt. Solche Waagen sind ab Werk geeicht und tragen die Kennzeichnung „M“ auf dem Gerät selbst und auf der Verpackung. Der GEO-Wert gibt bei vom Hersteller geeichten Waagen an, für welchen Aufstellungsort die Waage geeicht ist. Dieser GEO-Wert befindet sich auf der Waage sowie der Verpackung. Genaueres ist der GEO-Wert-Tabelle (siehe Kap. 11) zu entnehmen.

Remarques

Les balances vérifiées/admissibles à la vérification font l'objet d'une approbation de modèle UE. L'année de la vérification primitive est indiqués à côté de la marque CE. Ces balances sont vérifiées d'origine et portent la marque „M“ sur l'appareil lui-même et sur l'emballage. Le valeur GEO indique le lieu d'utilisation pour lequel la balance été vérifiée. Ce valeur GEO se trouve sur la balance ainsi que sur l'emballage. Veuillez trouver plus de détails dans le tableau GEO (voir chap. 11).

Notas

Las balanzas verificadas/verificables cuentan con una aprobación de modelo UE. El año de la primera verificación está indicado al lado del distintivo CE. Estas balanzas están verificadas en fábrica y llevan la designación „M“ sobre el propio aparato y sobre el embalaje. El valor GEO indica el lugar de ubicación por lo cual la balanza está verificado. El valor se encuentra sobre la balanza así como sobre el embalaje. Por favor toman demás detalles de la tabla GEO (ver cap. 11).

Avvertenza

Per le bilance approvate esiste un'approvazione CE del tipo. L'anno della prima verifica è indicato a fianco della marcatura CE. I tipi marcati con un contrassegno „M“ su sfondo verde peino possono essere impiegati da subito. Il coefficiente GEO di bilance omologate indca per quale luogo la bilancia è stata omologata. Questo coefficiente GEO si trova sulla bilancia e sull'imballo. Ulterioi informazioni vedi tabella coefficiente GEO (vedi cap. 11)

3. General Safety Instructions

Duties of the owner-operator

- Adhere to national accident prevention prescriptions and the operator's work, operating and safety prescriptions.
- Adhere to all of the crane manufacturer's safety prescriptions.
- Have crane scale, crane and load suspension equipment checked at least every two years by a specially trained employee.
- Record test results and keep in test book.

Organizational measures

- Only trained and instructed persons may operate the appliance.
- Make sure that the instruction manual is always available on the installation site of the crane.
- Have installation, commissioning, maintenance and repairs carried out by specially trained personnel only.
- Only use original replacement parts.

Intended use

- Use the crane scale exclusively for lifting and weighing freely moveable loads.
- Failure to adhere to prescriptions when using the appliance may result in injury. For example, the following is not permitted:
 - exceeding the permissible nominal load of the crane, crane scale or any type of load attachment equipment,
 - transporting persons,
 - pulling loads at an angle,
 - tearing loose, pulling or dragging loads.
- Changes or modifications to the crane scale or the crane are not permitted.

Safety conscious working methods

- Do not stop under suspended loads.
- Only position the crane so that the load is lifted vertically.
- Wear personal safety equipment (helmet, safety gloves) when working with the crane and crane scale.

Decommissioning and storage

- Remove the crane scale from the crane and remove all load attachment equipment from the crane scale.
- Remove battery block (large construction) from the crane scale if the crane scale is out of use for an extended period of time.

4. Crane scale at a glance

The crane scale is a versatile and economic solution for overhead material handling and weighing applications, i.e. recycling, metal works, machine repair and rebuilding, transport and logistics.

Optional infrared remote control makes operation even easier.

4.1 Overview

Small construction:

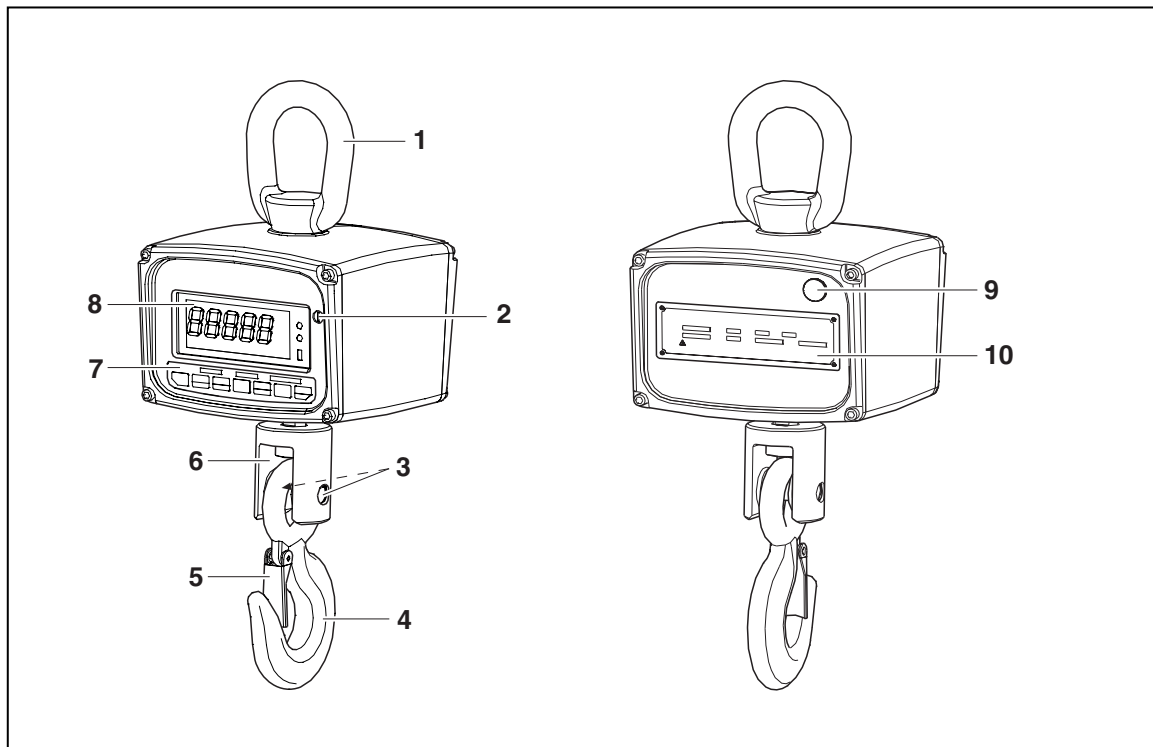

- | | | | |
|---|--------------------------|----|-----------------------------------|
| 1 | Eye | 6 | Connecting pipe |
| 2 | Gauge propeller | 7 | Keyboard |
| 3 | Retaining pins (2 items) | 8 | Display |
| 4 | Hook | 9 | Cover battery charging connection |
| 5 | Safety clip | 10 | Nameplate |

Large construction:

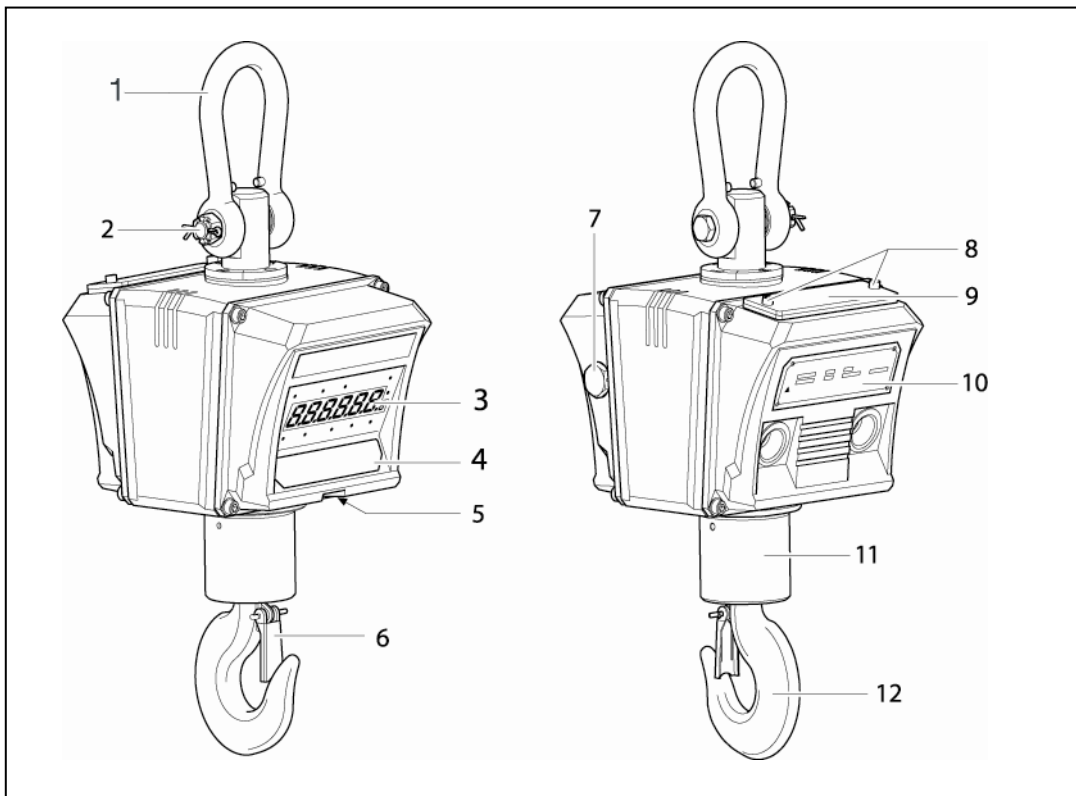

- | | | | |
|---|------------------------------|----|---------------------------|
| 1 | Eye | 7 | Gauge propeller |
| 2 | Splint | 8 | Battery screw |
| 3 | Display | 9 | Battery and battery cover |
| 4 | Keyboard | 10 | Nameplate |
| 5 | Window for IR remote control | 11 | Swivel joint |
| 6 | Safety clip | 12 | Hook |

4.2 Display

Small construction:

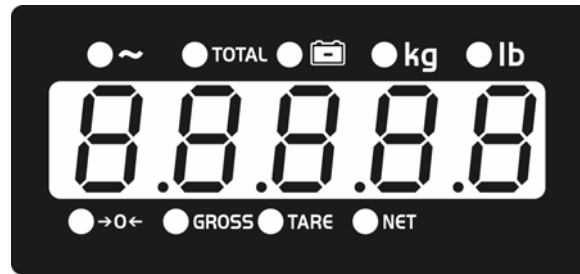

The weight display is a 5 digit LED display.

Large construction:

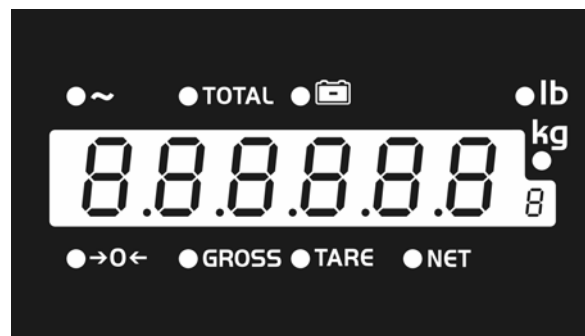

The weight display is a 6 digit LED display (big numbers). The small number on the right hand side indicates the current accumulator number.

LED	Meaning	The LED will illuminate when ...
~	Movement	The scale is in motion
Total	Total	The display shows the accumulated weight or the number of posts
BAT	BAT low	Battery falls below a certain value
kg		The weight unit currently shown is Kg
lb		The weight unit currently shown is lb
→0←	Zero	Weight is approximately +/- ¼ d around the zero point
Gross	Gross	The scale shows the gross weight
Tare	Tare	The scale shows the tare weight
Net	Net	The scale shows the net weight

4.3 Keyboard

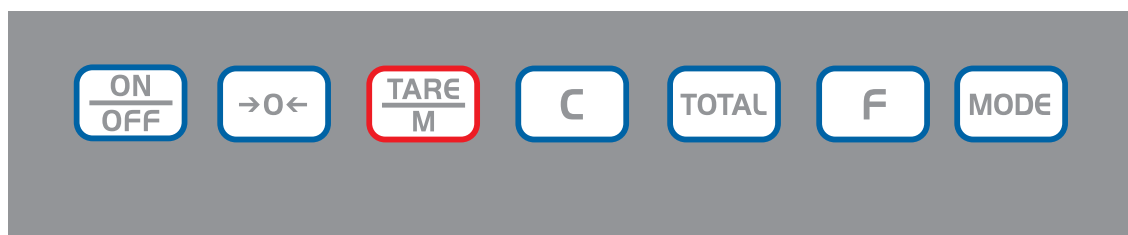

Key	Meaning	Functional Description
On/Off	On / Off	Switches the scale on or off...
→0←	Zero / master	Corrects the zero point of the scale The display is set to zero. Only use this key in gross mode.
TARE/M	Tare/M	In gross mode this button saves the current weight value as tare weight. The scale will display the net weight 0
C	Delete	In net mode: the scale returns to gross mode In gross mode: the scale starts a self-test In weight hold mode: the scale returns to weighing mode
TOTAL	Amount / maximum	The current weight value is added to the amount memory, the Total LED will blink for 3 seconds.
F	Call / stop	When pressed repeatedly the crane scale displays the tare value, the accumulated value, the number of items and the gross value.
MODE + →0←		Access user menu to set parameters, see chapter 7
MODE + TARE/M		Checks, saves and calls up the tare weight
MODE + TOTAL		The heaviest load of the last weighings shall be shown
MODE + F		A stable weight value shall be maintained (frozen)

4.4 Remote control

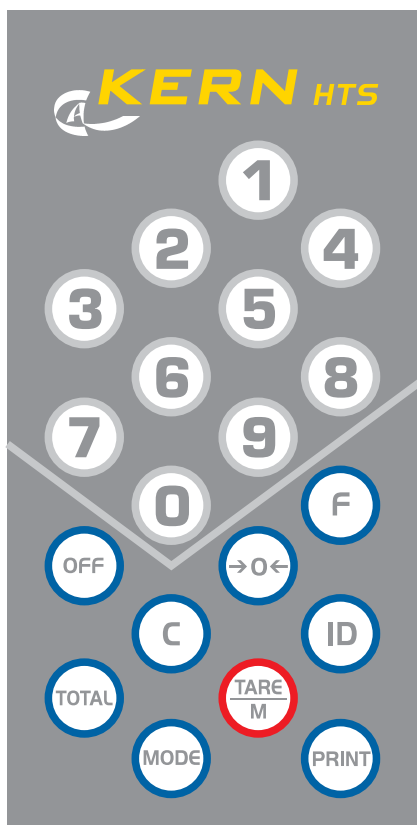

The infra-red remote control can operate the scale as the keyboard does. In addition the remote control adds 10 numerical keys: 0 to 9.

The red LED lights every time a key is pressed.

5. Commissioning

5.1 Unpacking (small construction)

⇒ Ensure that the all parts are accounted for.

- Crane scale
- Battery charger
- Remote control
- Operating Instructions

5.2 Unpacking (large construction)

 <p>CAUTION</p>	<p>Risk of straining your back! The crane scale is compact and relatively heavy.</p> <p>⇒ Remove the scale from the shipping container only with assistance of another person.</p> <p>⇒ Use a power-lifting device such as a crane or forklift.</p> <p>⇒ Secure the scale to ensure it doesn't drop when lifting.</p>
---	---

⇒ Ensure that the all parts are accounted for.

- Crane scale with lower hook
- Upper shackle
- Battery pack and battery charger
- Remote control
- Operating Instructions

5.3 Recharge the battery

A sealed, rechargeable lead-acid battery powers the crane scale.

 <p>CAUTION</p>	<p>Damage to the crane scale!</p> <ul style="list-style-type: none">⇒ Only use the battery charger provided with the crane scale.⇒ Check that battery charger, cables and mains plug are in good order and condition.⇒ Do not use the crane scale while charging.
---	--

Loading (small construction)

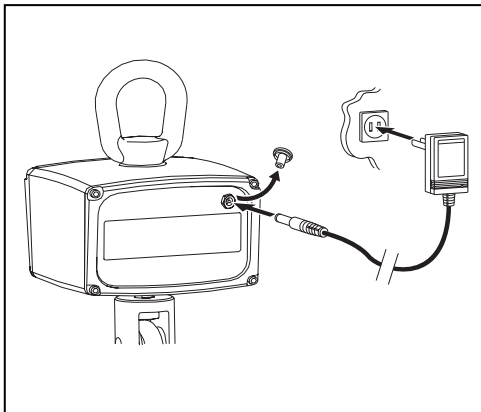

1. Take off the loader connector cover at the back of the crane scale.
2. Connect the battery charger on the one end to the battery pack connector and on the other end to the power outlet (mains). During charging, the charger indicator displays red.
3. The battery is fully charged, when the charger indicator displays yellow. The battery charges completely in 15 hours.

Loading (large construction)

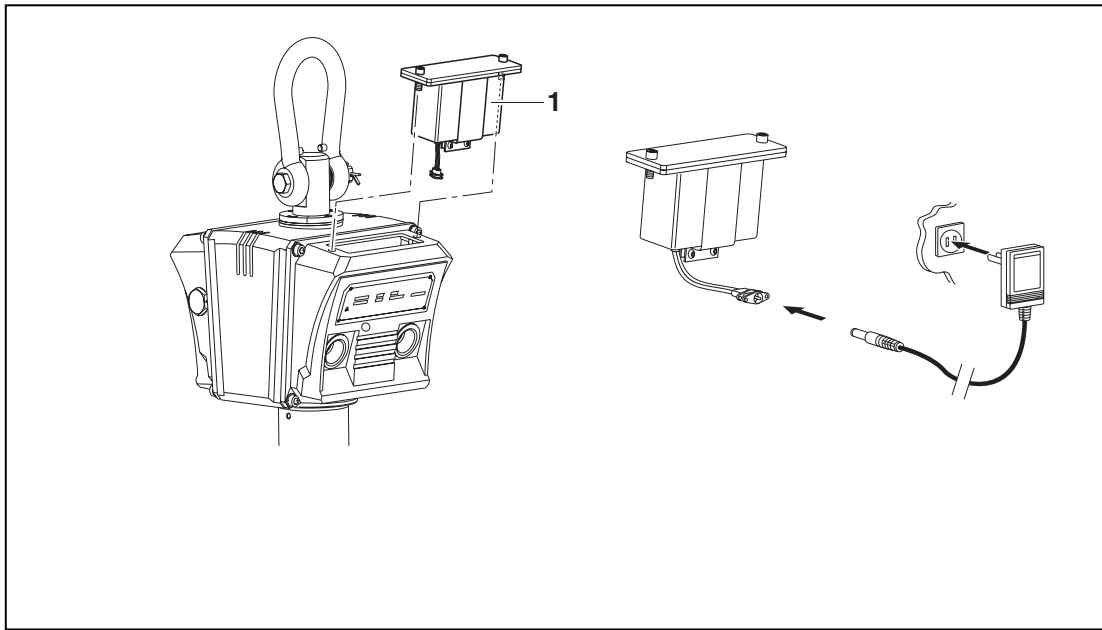

1. Undo the 2 screws of the battery cover on top of the crane scale and pull out the battery pack (1).
2. Unplug the battery pack from the connector in the housing.
3. Connect the battery charger on the one end to the battery pack connector and on the other end to the power outlet (mains).

During charging, the charger indicator displays red.

4. The battery is fully charged, when the charger indicator displays yellow.

The battery charges completely in 15 hours.

5. Use the additional battery pack for operation during charging. For mounting the battery pack proceed in reverse order.

5.4 Suspend scale

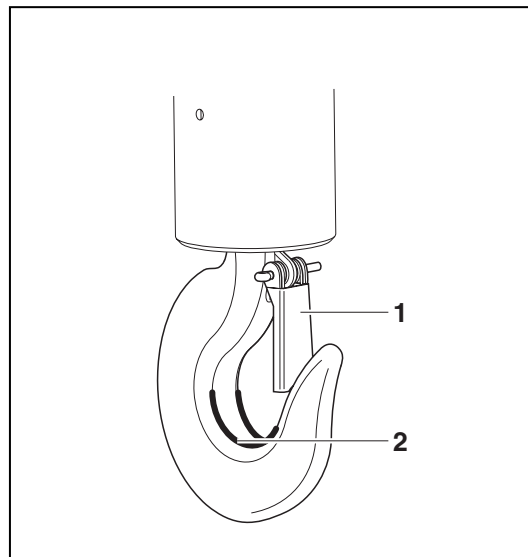

Pre-condition



Your crane must have a safety latch (1) to prevent the crane scale from falling when there is no load.

If there is no safety latch or the safety latch is damaged, please contact the crane manufacturer to obtain a hook with this safety feature.

- ⇒ Hang the crane scale from the bottom hook of a crane and lock the secure latch. The crane scale's upper shackle should rest in the saddle (2).

6. Operation

6.1 Safety instructions

	 Danger Risk of injury due to falling loads!
	<ul style="list-style-type: none">⇒ Always operate with great care according to the general rules for operating a crane, see chapter 1.⇒ Never walk or stand under hanging loads.⇒ Do not exceed the rated load capacity of the crane, crane scale or any load bearing item attached to the crane scale.⇒ Do not use crane scale for transporting loads

6.2 Load the crane scale

For good weighing results note the following, for figures see next page:

- ⇒ Do use hardware that creates single point attachments and allows the scale freedom of alignment.
- ⇒ Do not use oversize interface hardware which restricts single point loading.
- ⇒ Do not use multiple attachments.
- ⇒ Do not push or pull the load or the loaded scale.
- ⇒ Do not pull laterally on the hook.

Loading the scale

1. Position the crane scale hook over the load.
2. Lower the crane scale until the load can be attached to the scale hook. Reduce speed when reaching the appropriate level.
3. Attach the load to the hook. Make sure that the scale hook latch is closed. If slings are used to handle the load, make sure that the slings are fully seated in the saddle of the scale hook.
4. Start lifting the load slowly.

If slings are used to handle the load, make sure that the load is properly balanced and that the slings are positioned properly.

Loading small construction:

Do use hardware that creates single point attachments and allows the scale freedom of alignment

Do not push or pull

Do not pull laterally on the hook

Do not use oversize interface hardware which restricts single point loading

Do not use mutiple attachments

Loading large construction:

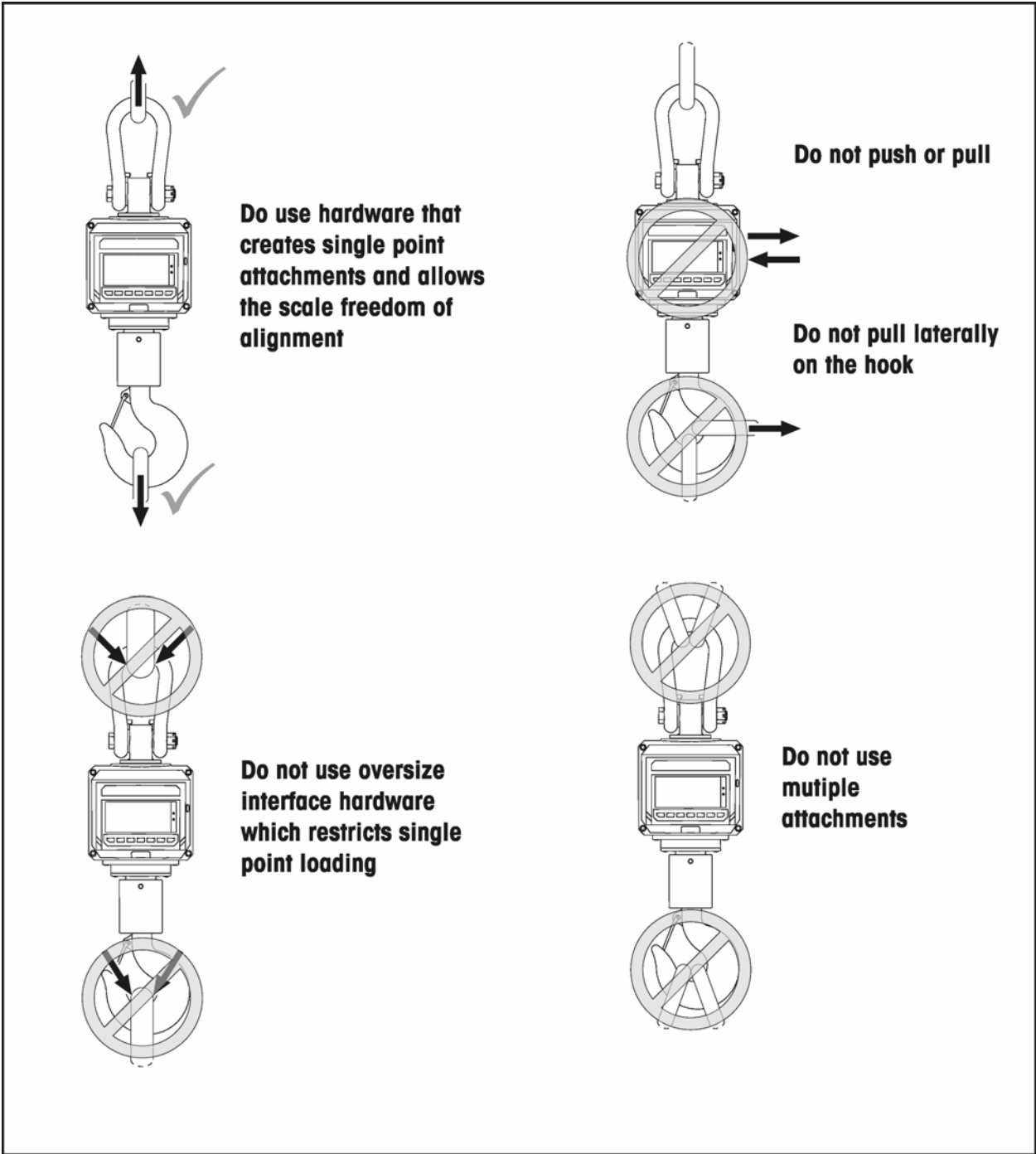

6.3 Turn on/off

Switching on

- ⇒ Press and hold the **On/Off** key on the keyboard of the scale.
The display illuminates and the scale runs a self test.

The self test is complete when weight value 0 is shown on the display. The crane scale works in gross mode.

Note:

Switching on is only possible via the keyboard of the scale.

Switching Off

- ⇒ Press and hold the **On/Off** key on the keyboard of the scale.
- or
- ⇒ Press the **Off** key on the remote control.

6.4 Reset scale

For best weighing results set the empty scale to zero before weighing.

Resetting is only possible if the weight value shown is within the preset zero area (see user menu, chapter 8.3) and if the scale is not moving, i.e. the „LED ~“ is not lit up.

Manual setting to zero

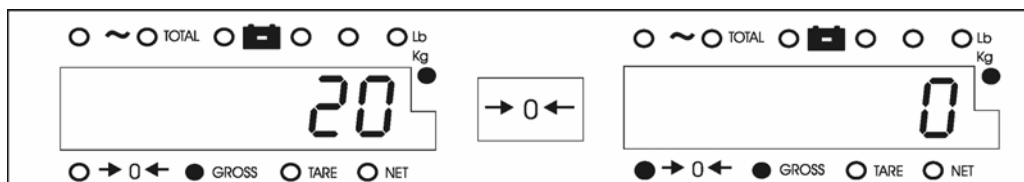

- ⇒ Press button **→0←** in gross mode.
0 (kg) shall appear in the display and "LED **→0←**" shall illuminate.

Auto zero with power up

With this function activated in the user menu (see chapter 8.3), the scale is automatically set to zero after powering up.

6.5 Taring

Taring is only possible if the scale is not in motion, i.e. the motion „LED ~“ is not lit. Once the tare weight is accepted the scale is working in the net mode.

Manual taring

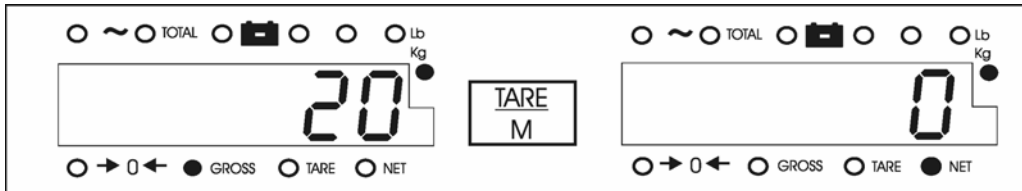

⇒ In gross mode press the **Tare** key. The scale stores the weight value as tare value. The display shows 0 (kg) and the Net LED lights.

Numeric tare

When you know the tare weight of the container, you don't have to weigh and tare the empty container, you can enter the tare weight on the remote control.

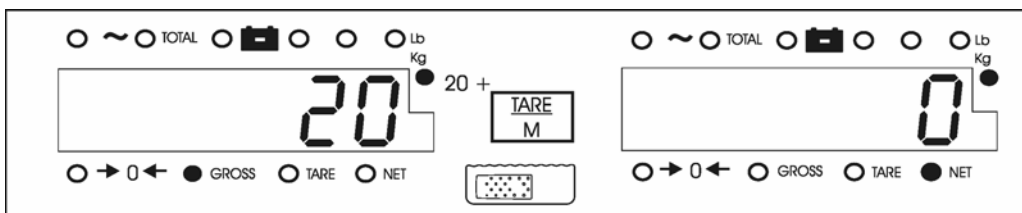

⇒ In gross mode enter the known tare value on the remote control, then press the **Tare** key. The display shows the net weight and the Net LED lights.

Call up current tare weight

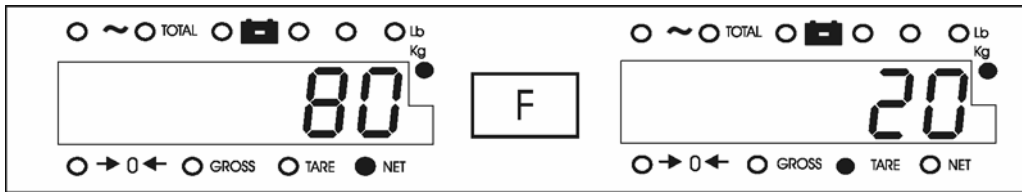

⇒ In net mode press the **F** key.

The tare weight is displayed and the Tare LED lights.

Note:

With the **F** key you can switch between net and tare weight. See chapter 6.7 for working with the accumulation function.

Clearing tare weight

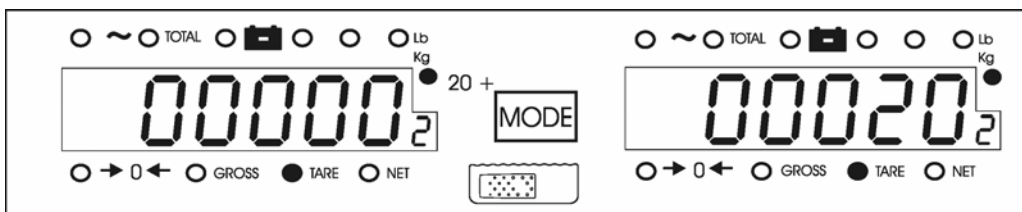

⇒ In net mode press the **C** key.

The tare weight is cleared.

The gross weight is displayed and the Gross LED lights.

6.6 Working with the tare weights saved

The crane scale has 10 memories (storage areas 0...9) for tare weights.

The first storage space (0) shall be used for numerical and manual tares. Weights saved here shall be overwritten with manual or numerical tares. For saving tare weights that are used frequently, storage spaces 1 ... 9 should be used.

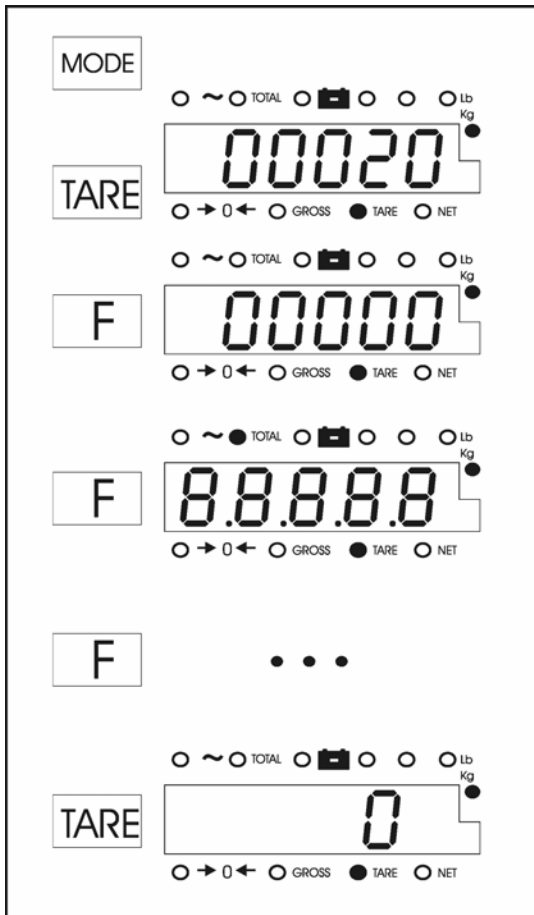

Calling and taking over the tare weights saved

1. Press mode and tare buttons consecutively.

The content of the first tare memory shall be displayed. The number of the storage area shall be represented by a small figure on the right.

2. Press key F to call the second tare memory.

3. Press key F to call additional tare accumulators.

4. Press the tare button to take over a saved tare weight.

The crane scale changes into net mode and uses the tare weight saved.

Note

You can transfer into gross mode at any time by pressing button **C**.

Save new tare weight

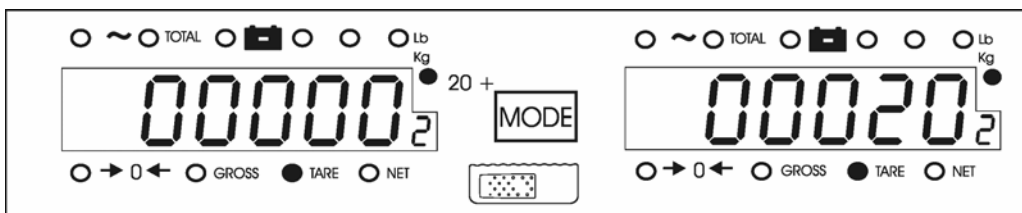

1. Select storage area as described above.
2. Enter tare weight using the remote control and confirm with the **Mode** key.

or

⇒ Press key →0← and enter the tare weight with the tare and F keys.

Note

Tare weight entries that have not been confirmed may be cancelled by pressing the →0← key.

6.7 Weighing

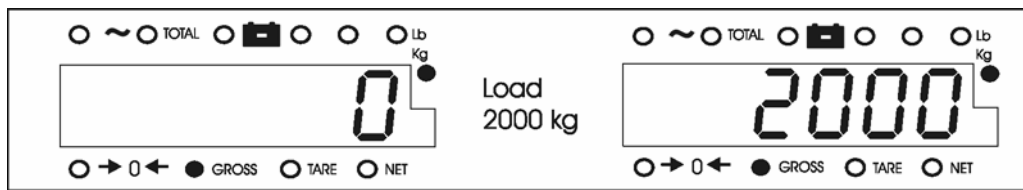

- ⇒ Load the crane scale.
The weight value is indicated immediately.

Note

The crane scale offers optical weighing help, i.e. the display blinks if the weight value is not within boundaries set. In addition, "weighing with boundary value monitoring" (see chap. 8.3) has to be set in the service menu and a higher or lower weight shall be set in the user menu (see chapter 5.4).

6.8 Accumulation

Manual or automatic accumulation must be activated in the service menu, see chapter 8.3.

Manual accumulating

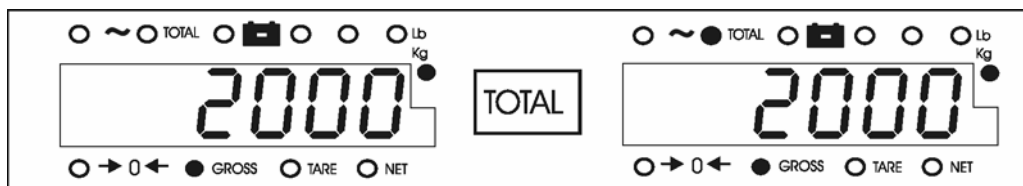

- ⇒ In gross or net mode, press the **Total** key to add the weight value to the accumulator. The Total LED is lit. The internal item counter is increased by 1.

Automatic accumulating

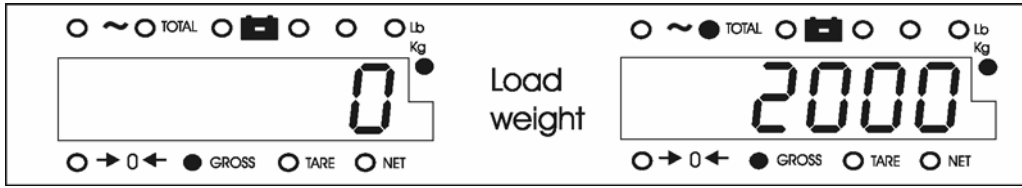

⇒ Load a weight equal or heavier than the minimum accept limit.
The weight is automatically added to the accumulator. The Total LED is lit. The internal item counter is increased by 1.

Notes

- The weight is accumulated automatically if it is equal or heavier than the minimum accept limit set in the service mode, see chapter 8.3.
- Between successive weighings the weight value must decrease by 10 digits to be recognized as a new accumulation value.
- When the accumulated weight exceeds 8 digits or the item counter exceeds 4 digits, FULL is displayed and the Total LED is flashing for 5 seconds. The last accumulating is invalid!

Recall accumulation values

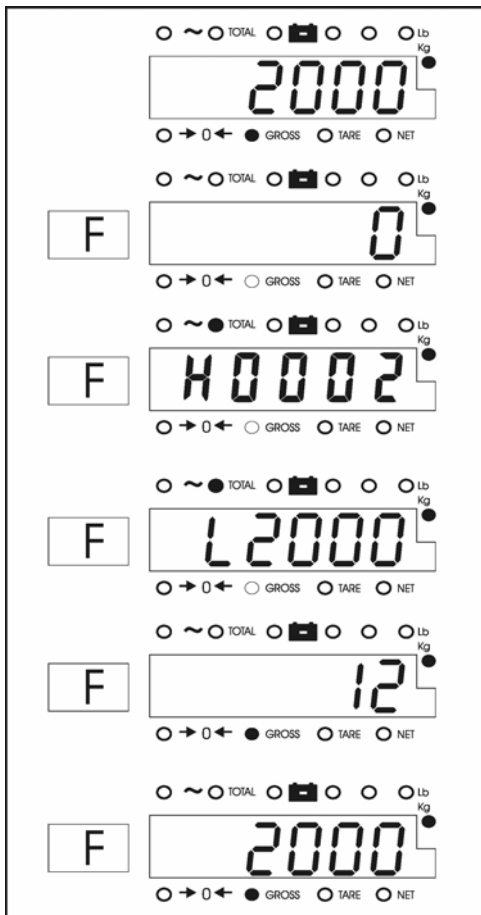

When pressing the **Recall** key repeatedly the crane scale displays the following values:

Tare weight

First 4 digits of the accumulated weight

The last 4 figures of the accumulated weight. In this example the accumulated weight is 22,000kg.

Number of items accumulated

Back to gross mode

Clearing the accumulator

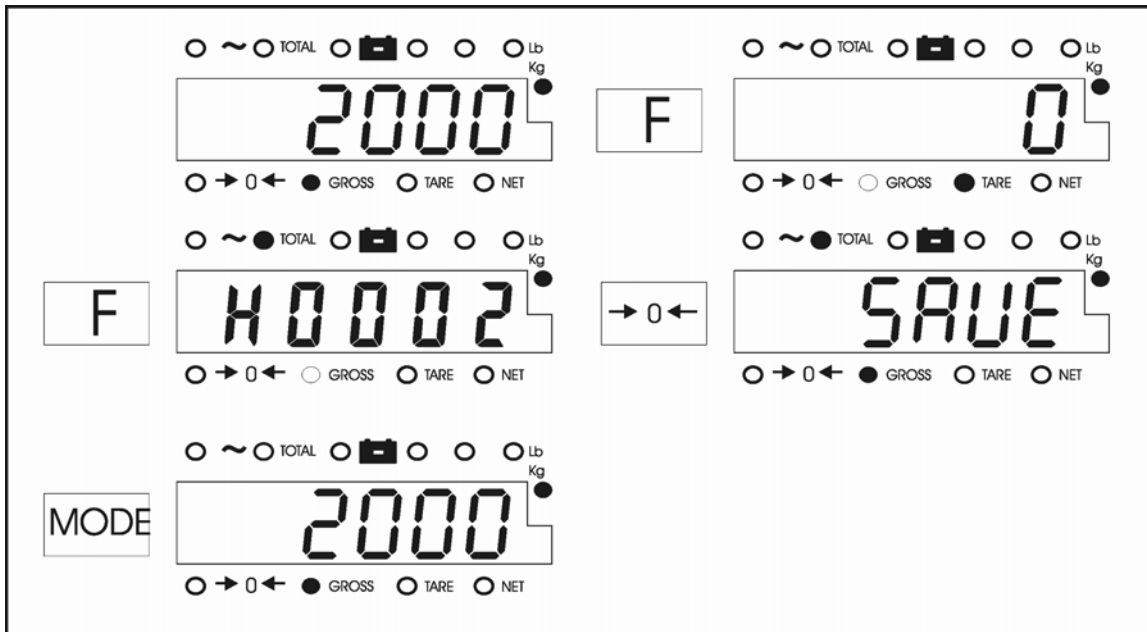

1. Press repeatedly the **F** key to recall the first digits of the accumulated weight (H...).
2. Press key **→0←** in order to delete the amount accumulator.
3. Confirm **SAVE** with the **mode** key.
The accumulator is cleared, the crane scale is back to gross mode.

6.9 Show peak load

In addition, stop mode must be set in the service menu, see chap. 8.3. In this instance the accumulation function is not available.

In this mode the crane scale can display and hold the detected maximum weight.



⇒ Press **Mode** and then **Total** to show the heaviest load of the last weighing.

Clearing the peak weight

⇒ When the highest load is shown, press buttons →0← and **C**. The display returns to the actual gross weight.

6.10 Stop weight value (freeze)

Once a stable weight value is detected, you can "freeze" or lock the weight value displayed until it is cleared for the next weighing.

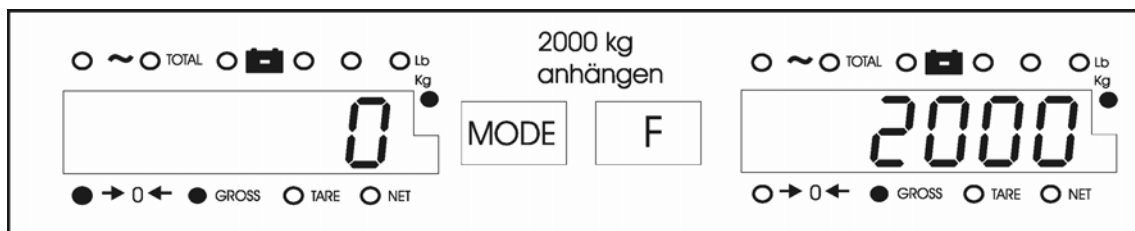

⇒ Press the buttons **Mode** and **F** to "freeze" or hold the current weight value. It will be displayed as long as it isn't cleared.

⇒ To clear the "frozen" or locked weight, press the **C** key.

6.11 Battery operation

For optimum battery operation please observe the following:

- ⇒ Do not recharge the battery until it has been fully discharged.
- ⇒ Charge the battery at least every 3 months to keep it in good condition.
- ⇒ When the crane scale is not in use for a long time, remove the battery.

Battery indicator

There are two levels of battery indicators:

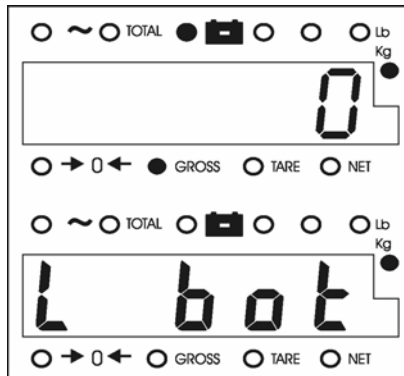

⇒ With the **BAT LOW** LED lit, charge the battery **soon**.

⇒ With the **L bat** display, charge the battery **immediately**

Notes

- The battery is not warranted due to its service time is greatly influenced by individual use.
- Battery charge is less than normal if the battery is not used for a long time, e.g. for more than 2 months. To return the battery to normal operation conditions cycle the battery at least 3 times by charging it and using it until it is fully discharged.
- Battery charge and scale operation duration will decline with use. We recommend replacement of the battery after 300 charging cycles.

Checking battery capacity

In the self test the crane scale checks the display and the battery capacity.

⇒ In gross mode press the **C** key. The following is displayed:

- 000000
- 111111
- ...
- 999999
 - bat x, with x = 1 (low) ... 4 (high)

6.12 Operation with remote control

The remote control can be operated at distances up to 15 meters.

You can operate all functions except switching on via the remote control. With the remote control the additional function **numeric tare** is possible.

⇒ Aim the top of the remote control to the front of the crane scale. **Notes**

- The red LED must light up with every key touch. If it fails to light up, the batteries of the remote control must be changed, see chapter 10.3.
- Change the batteries every 2 months.

7. User menu

In the master mode you can modify parameters concerning your specific weighing application.

7.1 Overview

The crane scale menu consists of two areas: The user menu and the service menu for service technicians, see chapter 8. Operation is the same in both areas. The user menu parameters are represented by numbers in the display.

Parameter		Factory settings	
No.	Name	Value	Meaning
F3.1	Sleep mode	1	On
F3.6.1	Upper boundary value		
F3.6.2	Lower boundary value		
F3.6.3	Weighing help	0	Off
F3.7	Save status	0	Off
F4.3	Display test	0	Skip display test
F4.4	Keyboard test	0	Skip keyboard test
F5.1	Exit menu	1	Save changed settings

If no factory settings have been given, then they depend on the model or on the country and its respective laws on measures and calibration.

7.2 Accessing user menu

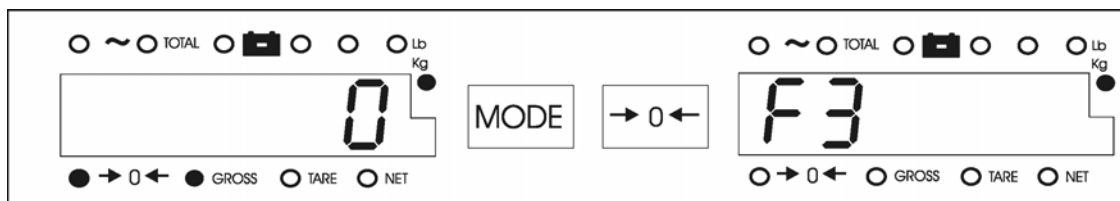

- ⇒ Press the buttons **Mode** and **→0←** simultaneously.
The final parameter F3 group of the user menu shall be displayed. No LED is lit. The scale is ready for modifying parameters.

7.3 Operation in menu

Display in user menu

The display is divided in 3 groups:

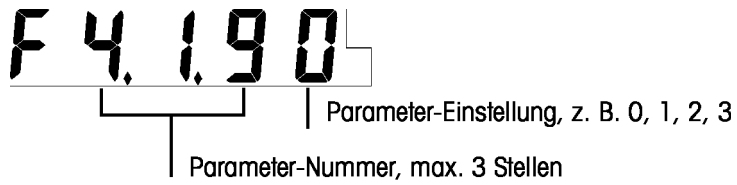

Kennzeichnet den Mastemode

Selecting parameter groups or settings

Example 1: to get from parameter group F3 directly to parameter group F4

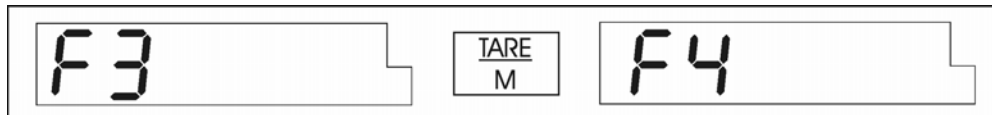

⇒ Press the **Tare** key to get to the next parameter group.

Example 2: In order to access sub-parameter F3.1 from parameter group F3



⇒ Press the **Mode** button to access the sub-parameters.

Example 3: change setting for parameter F3.1 from 0 to 1

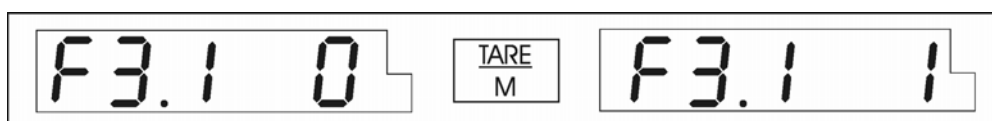

⇒ Press the **Tare** key to change the parameter setting.

Returning to the previous step

Example 1: to return from parameter group F4 to parameter group F3

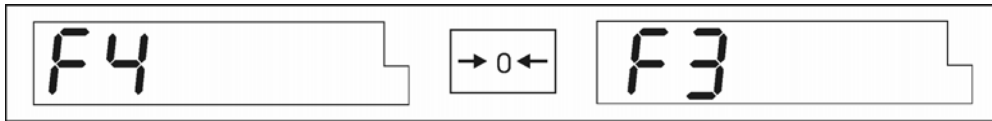

⇒ Press key →0← to access the previous parameter group.

Example 2: to return from parameter group F3.8 to parameter group F3.7

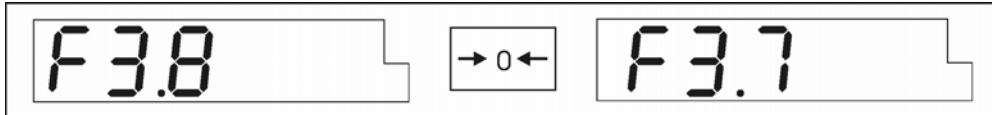

⇒ Press key →0← to access the previous parameter group.

Confirming selected parameter (settings)



⇒ Press **Mode** button.

The selected parameter (setting) is confirmed and the next master mode step is displayed in the user menu.

Enter numerical values

The most comfortable way to enter numerical values is via the remote control.
On the crane scale keyboard use the **Tare** and **F** keys.



⇒ Use the **F** key to increase the flashing digit (in the example: 0) by 1.

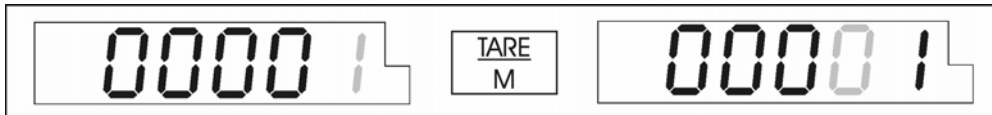

⇒ Use the **Tare** key to move the flashing digit (in the example: 1) one digit to the left.
The leftmost digit will move to the rightmost digit.

⇒ Use the **Mode** key to confirm the entry and proceed to the next step.

End menu

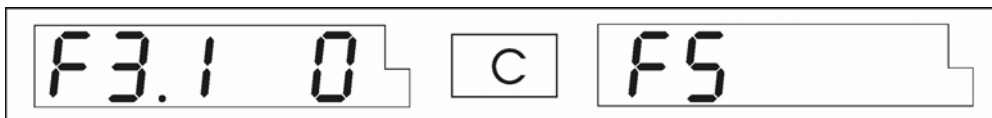

⇒ Press button **C**.

F5, the final parameter group of the user menu shall be displayed.

For further steps see chapter 7.4 or chapter 8.3.

7.4 Description of the user menu

Factory settings are printed in **bold**.

F3.1 – Sleep mode

The crane scale will enter sleep mode if the keyboard is not in use and if the weight has not changed for 5 minutes. SLEEP will be displayed. To escape the sleep mode, press a key on the keyboard or on the remote control.

- 0 Sleep mode is switched off
- 1 Sleep mode **activated** (factory setting)

F3.6.1 – upper boundary value

This parameter only appears when the “boundary value monitoring” weighing mode is selected in the service menu.

After selecting the parameter, the current upper boundary value set shall appear.

⇒ Enter the upper boundary values with the remote control.

or

⇒ Enter the upper boundary value with the buttons **Tare** and **F**.

F3.6.2 – lower boundary value

This parameter only appears when the “boundary value monitoring” weighing mode is selected in the service menu.

After selecting the parameter, the current lower boundary value set shall appear.

⇒ Enter the lower boundary values with the remote control.

or

⇒ Enter the lower boundary value with the buttons **Tare** and **F**.

Note

The lower boundary value must be smaller than the upper value.

F3.6.3 – initial weight help

This parameter only appears when the “boundary value monitoring” weighing mode is selected in the service menu.

- 0 **No** optical initial weight help (factory setting)
- 1 The weight display flashes when weight falls below the lower boundary value or exceeds the upper boundary value.

F3.7 – Memory retention

When memory retention is enabled, the crane scale returns to the last status (zero point, gross/net mode etc.) when powering up.

0 Save status **off** (factory setting)

1 Save status on

F4.3 – display test

⇒ Press the **Mode** key in order to skip the keyboard test and continue with step F4.4.
or

⇒ Press the **Tare** key to enter the keyboard test (F4.3 1), then press the **Mode** key to start the keyboard test.

The following is displayed:

- All possible numbers: from only zeros through only nines,
- all LEDs illuminate

When F4.4 is displayed, the display test is finished.

F4.4 – keyboard test

⇒ Press the **Mode** key in order to skip the keyboard test and continue with step F5.1.
or

1. Press the **Tare** button to select keyboard test (F4.41) then press the **Mode** button again in order to start the keyboard test.

E is displayed.

2. Press the **Mode** button and then press all of the keys on the keyboard from right to left. The number in the display indicates the key number (from the right) to be pressed next.

Pressing the →**0**←-button ends the keyboard test and the next parameter (F5) appears.

F5.1 – End menu

1 Saves settings

2 Restores the most recently saved parameters

8. Service menu

8.1 Overview

Parameter		Factory settings	
No.	Name	Value	Meaning
F1.2	Digital filter	2	medium
F1.5	Taring	1	On
F1.6.2	Automatic zero points	0	Off
F1.6.3	Reset area when switching on	2	+/-10 %
F1.6.4	Reset area for manual reset	1	+/-2 %
F1.7.1	Area for motion sensor	1	+/-0.5 d
F1.8	Edit weighing unit		
F1.9	Select capacity		
F1.10	Select resolution		
F1.11	Calibrate mode	0	Standard
F1.12	Calibration	0	Skip calibration
F1.13	Reset	0	Skip reset
F1.14	Set tension	0	Skip set tension
F2.4.1	Minimum weight for accumulation		
F2.4.2	Accumulation	0	Off
F2.5	Weighing mode	0	normal
F2.6	Switching weight unit	0	Off
F2.7	Geo-value		
F3.4	No function		
F4.1	Expanded display	0	Off
F5.1	Exit menu	1	Save changed settings

If no factory settings have been given, then they depend on the model or on the country and its respective laws on measures and calibration.

8.2 Access service menu

Access service menu, small construction

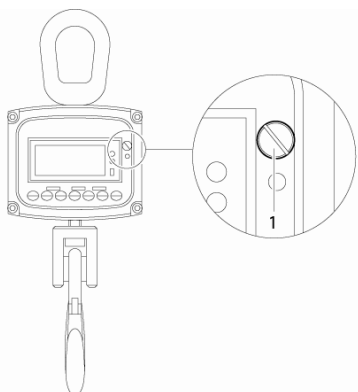

1. Remove the sealing screw (1)*.
2. Switch on the balance:
3. Press the switch in the hole.
The display shows F1. The scale is ready for modifying parameters.

Access service menu, large construction

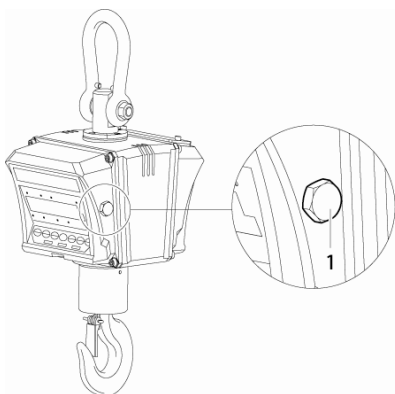

1. Remove the sealing screw (1)*.
2. Switch on the balance:
3. Press the switch in the hole.
The display shows F1. The scale is ready for modifying parameters.

Operation in service menu

Navigation in the service menu is the same as in the user menu, see chapter 7.3.

* In verified scales, the seal must be destroyed for this procedure. The removal of the seal will annul the verification, see chapter 8.4.

8.3 Description of service menu

Factory settings are printed in **bold**.

F1.2 – Digital filter

The digital filter stabilises the weight display when

- 0 Filter off
- 1 Filter setting low
- 2** Filter setting **medium** (factory setting)
- 3 Filter setting high

F1.5 – Tare operation

Tare operation can be enabled or disabled.

- 0 Tare function off
- 1** Tare function **on** (factory installation)

F1.6.2 – Auto zero operation

Zero setting within a set threshold value can be done automatically by the crane scale.

- 0** Automatic reset **off** (factory setting)
- 1 Automatic reset in +/-0.5 d area
- 2 Automatic reset in +/-1.0 d area
- 3 Automatic reset in +/-3 d area

F1.6.3 – Auto zero with power up

When the crane scale is powered up it will re-zero based on the tolerances below.

- 0** Automatic reset **off** when switching on (factory setting)
- 1 Automatic reset when switching on in +/-2% area
- 2 Automatic reset when switching on in +/-10 % area
- 3 Automatic reset when switching on in +/-100 % area

F1.6.4 – Manual zero operation

This setting affects the tolerance of the pushbutton or remote control zero.

- 0 Manual reset off
- 1 Manual zero operation with **zero range $\pm 2\%$** (factory setting)
- 2 Manual reset in reset area $\pm 20\%$
- 3 Manual reset in reset area $\pm 100\%$

F1.7.1 – Motion detection

With the motion detection you can determine the stability of the weight value. It affects the acceptance of a zero or tare request when the load is vibrating or moving.

- 0 Motion sensor switched off
- 1 **Motion detection range $\pm 0.5 d$** (factory setting)
- 2 Motion sensor in $\pm 1 d$ area
- 3 Motion sensor in $\pm 3 d$ area

F1.8 – Weight unit

The possible weight units depend on the capacity of your crane scale and on verification.

- 1 Edit weighing unit **kg**
- 2 Edit weighing unit lb $1 \text{ lb} \approx 0.454 \text{ kg}$

F1.9 – Capacity selection

After 2 seconds the current capacity is displayed.

⇒ Press key →**0**← and enter the tare weight with the **tare** and **F** keys.
or

⇒ Press the **Mode** key to confirm the displayed capacity.

Note

You can set a capacity equal to or less than the maximum capacity specified for your crane scale.

F1.10 – Not documented

Changes can not be made.

F1.11 – adjustment mode

The crane scale offers two adjustment procedures: Standard and 3 point adjustment, see F.1.12.

0 Standard adjustment (factory setting)

1 3 point adjustment

F1.12 0 – notes on adjustment

- Do not enter adjustment unless you have sufficient test weights, min. 20 % of the capacity.
 - For highest accuracy use test weights of 80 % or more.
 - Test weights should relate to the lowest significant digit, e.g. with a lowest significant digit of 5 kg the test weight should be a multiple of 5 kg.
- ⇒ Press the **Mode** key in order to skip the adjustment and continue with step F1.13.

or

- ⇒ Press the **Tare** key to enter adjustment (F1.12 1), then press the **Mode** key to start the adjustment procedure according to the setting in F1.11.

Standard setting

Display	Key	Description
E SCL *		Unload the scale
	Mode	The scale shall wait for a stable weight value
15 SCL ... 0 SCL		While counting down from 15 to 0 the scale records zero
Add L *		Attach test weight of at least 20% of capacity
	Mode	Confirm attachment of test weight
000000		Enter weight value for test weight
	Tare, F or remote control	Enter weight value
002000		Enter weight value for test weight
	Mode	Confirm weight value
15 SCL ... 0 SCL		While counting down from 15 to 0 the scale records span
CAL d		Adjustment complete. This message is displayed for 2 seconds.
F1.130		Next step in service menu

*When these displays appear, adjustment may be cancelled by pressing the →0← button.

3 point adjustment

Display	Key	Description
E SCL *		Unload the scale
	Mode	The scale shall wait for a stable weight value
15 SCL ... 0 SCL		While counting down from 15 to 0 the scale records zero
Add H *		Attach test weight of at least 50 % of capacity
	Mode	Confirm attachment of test weight
000000		Enter weight value for test weight
	Tare, F or remote control	Enter weight value
002000		Enter weight value for test weight
	Mode	Confirm weight value
15 SCL ... 0 SCL		While counting down from 15 to 0 the scale records high span
Add L*		Attach test weight of at least 10 % of capacity
	Mode	Confirm attachment of test weight
000000		Enter weight value for test weight
	Tare, F or remote control	Enter weight value
002000		Enter weight value for test weight
	Mode	Confirm weight value
15 SCL ... 0 SCL		While counting down from 15 to 0 the scale records low span
CAL d		Adjustment complete. This message is displayed for 2 seconds
F1.130		Next step in service menu

*When these displays appear, adjustment may be cancelled by pressing the →0← button.

F1.13 0 - Zero adjustment

This function allows re-zeroing after removing chains, slings and lifting devices used in calibration.

1. Press the **Tare** key to enter zero adjustment.
2. Remove all weight from the scale and then press the **Mode** key.
3. The scale counts down from 15 SCL to 0 SCL while recording zero.
4. When F14.1 0 is displayed, zero adjustment is finished.

F1.14 0 – Not documented

Changes can not be made.

F2.14 1 – minimum weight for accumulation

Immediately the actual minimum weight to be accumulated appears on the display.

⇒ Enter your minimum weight to be accumulated by the remote control.

or

⇒ Use the **Tare** and **F** keys to enter your minimum weight to be accumulated.

F2.4.2 – Accumulation mode

- 0** Accumulation **off** (factory setting)
- 1 Manual accumulating
- 2 Automatic accumulating

Note

With automatic accumulation, the weight value between 2 consecutive weighings shall decrease by at least 10 digits, in order to be recognised as a new accumulative value.

F2.5 – Weighing mode

- 0** **Normal** weighing (factory setting)
- 1 Stop mode

Note

- In the peak hold mode the scale displays the detected maximum weight and holds it. The Total LED is lit. Accumulation is not possible in this mode.
- If scales with boundary value monitoring have been selected, the parameter F3.6.x shall appear in the user menu.

F2.6 – changing weight units

- 0** **No** switching (factory setting)
- 1 Switching from lb to kg
- 2 Switching from kg to lb

F2.7 – geo value

For adjustment to local gravitational relationships.

The current geo values set are displayed.

1. The appropriate geo values of the tables can be found in chapter 11.
2. Press the **Tare** button and enter the appropriate geo values via remote control.

or

⇒ Press the **Mode** button in order to confirm the geo value displayed.

F4.1 – Expanded display

In expanded display operation the weight value is indicated with the internal interval.

- 1 (normal) resolution point = 10 internal resolution points
- 0** Enlarged display **off** (factory setting)
- 1 Enlarged display activated

F5.1 – End service menu

- 1 Save settings**
- 2 Restores the most recently saved parameters
- 3 Resets the factory settings **information**

When “restore factory settings” has been selected, "SURE" shall appear in the display. Confirm this enquiry with the **Mode** key.

8.4 Verification

General:

According to the EU guideline 90/384/EEC balances must be verified officially if they are to be used as follows (legally regulated area):

- a) For commercial transactions if the price of goods is determined by weighing
- b) For the production of medicines in pharmacies as well as for analyses in the medical and pharmaceutical laboratory
- c) For official purposes
- d) For the production of finished packages

In case of doubt, please contact your local office of weights and measures.

Verification information

An EU qualification approval is available for those balances marked as appropriate for verification in the technical data. In the event that the balance is applied in an area subject to verification as described above, it must be officially verified and re-verified at regular intervals.

Re-verification of a balance is carried out in compliance with the respective legal provisions of the states. The term of verification validity for balances in Germany, for example, is normally 2 years.

The legal provisions of the country of use are to be observed.

After verification the seal screw is plumbed with a seal thread.

Verification of the balance is invalid without the seal.

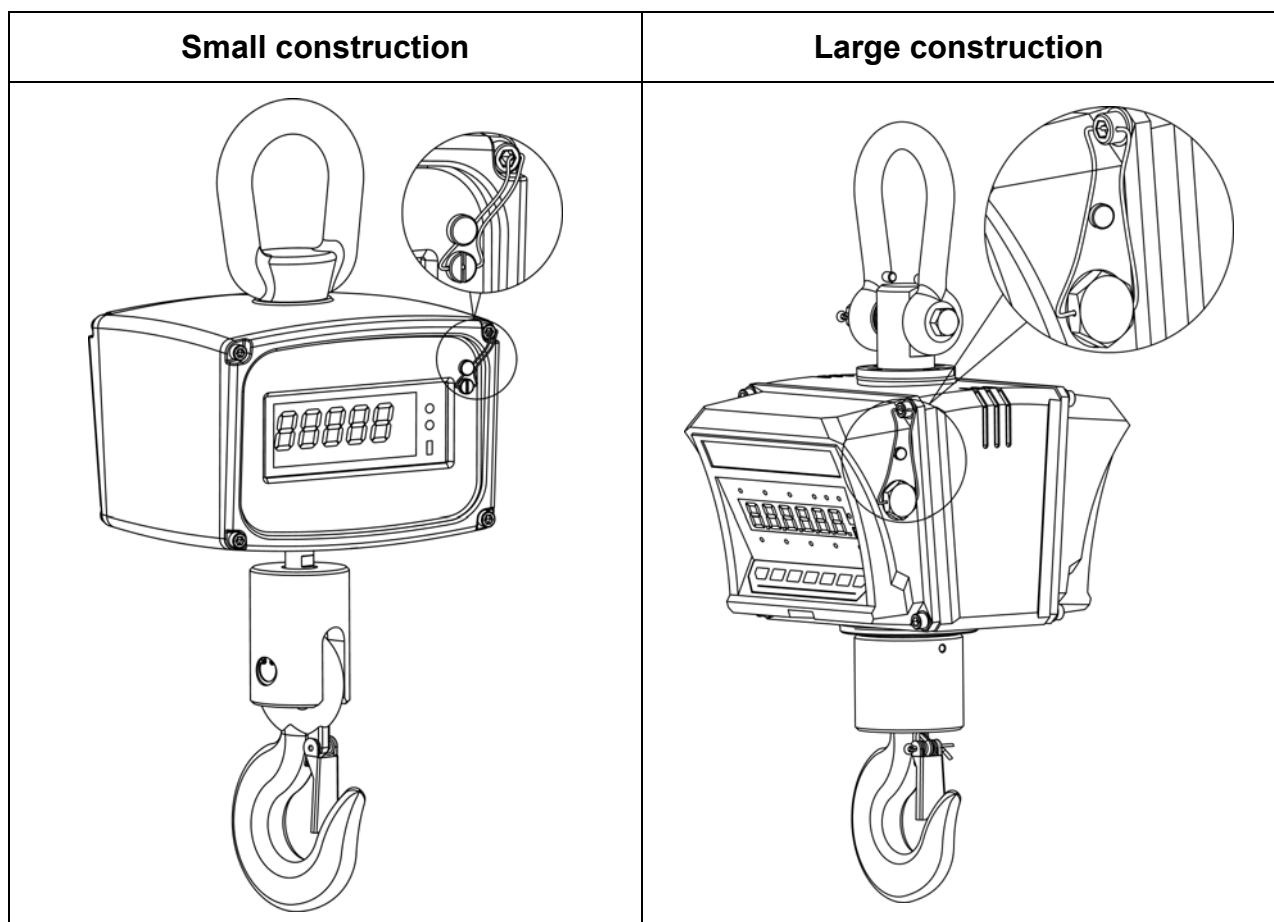

Position of the seal:



Balances with obligatory verification must be taken out of service if:

- **The weighing result of the balance is outside the maximum limits of operating errors.** Therefore load balance is regular intervals with known test weight (ca. 1/3 of the max. load) and compare with displayed value.
- **The date for subsequent or periodical verification has passed.**

9. Error messages

Error code	Fault	Remedy
E1, E2, E3	Internal error	⇒ Switch crane scale off and then on again ⇒ If message is still on, call Service
E35	Adjustment weight to low	⇒ Attach additional test weight
E37	Scale in motion	⇒ Re-adjust
Full	Overflow data accumulator	⇒ Data record deletion
	Underload, i.e. weight below power on auto zero limit	⇒ Unload the scale ⇒ Press button →0← ⇒ If message is still on, call Service
	Overload, i.e. weight is 9 digits over full capacity	⇒ Decrease the load ⇒ Check if the scale has not been damaged
Weight values are drifting	Internal error	⇒ Inform service
BAT LOW	Low battery voltage	⇒ Recharge the battery
L bAT	Battery power low, automatic switch off in one minute	⇒ Charge the battery immediately
SLEEP	Sleep mode, automatically entered when the weight has not changed and the scale was not in use for 5 minutes	⇒ Press any key on the keyboard of the scale or on the remote control
Remote control does not work	<ul style="list-style-type: none"> • IR windows dirty • Low battery voltage 	⇒ Clean the window on top of the remote control and the receiving window on the crane scale with alcohol and a clean cloth ⇒ Change the batteries of the remote control

10. Maintenance & Cleaning

10.1 Regular maintenance

 Danger	<p>Risk of injury and damage! The crane scale is part of the lifting gear! For safe operation observe the following:</p> <ul style="list-style-type: none"> ⇒ Have regular inspections be done by a qualified service technician, ⇒ Do the inspection according to the list below (for figures see next page), ⇒ For replacing damaged parts call Service.
--	--

Part	Check for	Limit	Remedy
Connecting pieces, split pins, set screws	Loosening		⇒ Call Service dpt. for replacing the damaged parts
	Deformation		
Surfaces of shackle and hook	Mechanical damage, e.g. unevenness		
Eyes and hooks	<ul style="list-style-type: none"> • Tear • Plastic deformation 		
Eyes and hooks	<ul style="list-style-type: none"> • Wear • Corrosion 	Actual dimensions <95% of original dimensions	
Eye	• Alignment of eyes	May not be twisted	
Opening hooks	• Deformation	Deformation > 10 % of original dimensions	
Hook	• Twisting	Twisting > 10°	
Safety clip	• Damage		

Small construction:

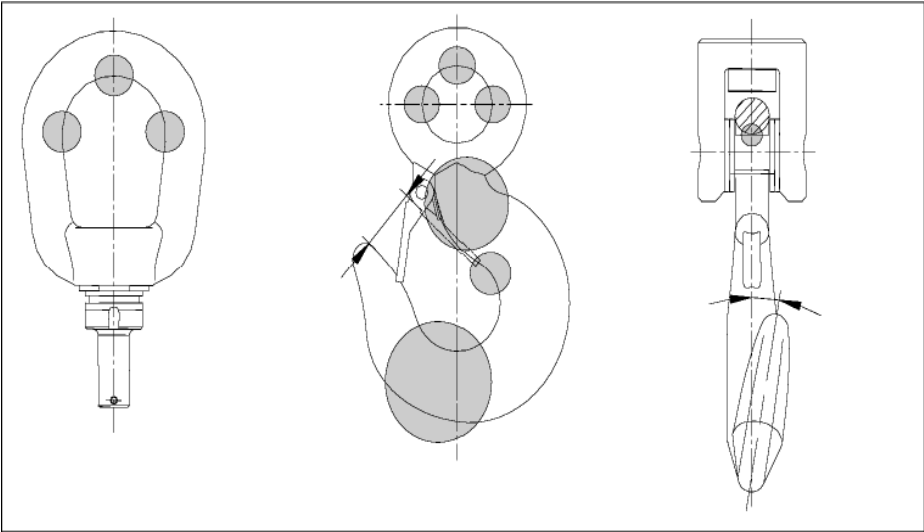

Large construction:

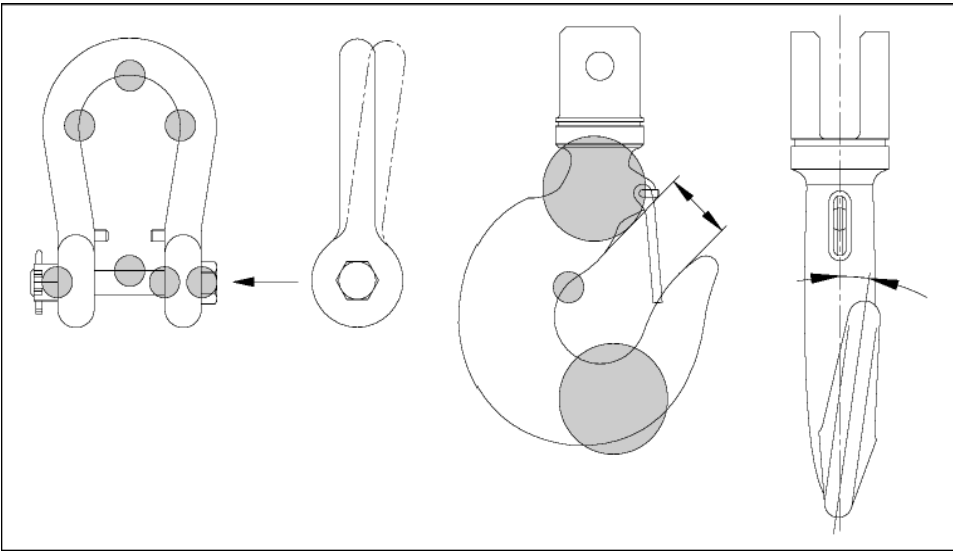

10.2 Cleaning

 <p>CAUTION</p>	<p>Damage to the crane scale!</p> <p>⇒ Do not use any type of industrial solvents or chemicals.</p>
---	--

⇒ Clean the keyboard and the display with a soft cloth that has been dampened with a mild window type cleaner or detergent.

10.3 Change the batteries of the remote control

To change the batteries, the remote control has to be taken from the yellow rubber housing.

1. Push the head of the remote control slowly out of the rubber housing through the upper hole on the back of the housing and pull the black remote control out.
2. Undo the battery compartment cover and replace the batteries. Be sure that the battery poles are positioned correctly.
3. Close the battery compartment and slip the remote control into the yellow housing.

11. Enclosure

11.1 Table of geo values

Northern or southern geographical breadth in degrees and minutes.	Height above sea level in metres										
	0	32	650	975	130	162	195	227	260	292	3250
	32	5	975	130	0	5	0	5	0	5	3575
Northern or southern geographical breadth in degrees and minutes.	Height above sea level in feet										
	0	10	213	320	426	533	640	746	853	960	1066
	10	60	0	0	0	0	0	0	0	0	0
Northern or southern geographical breadth in degrees and minutes.	Height above sea level in feet										
	60	21	320	426	533	640	746	853	960	106	1173
		30	0	0	0	0	0	0	0	60	0
0° 0' – 5° 46'	5	4	4	3	3	2	2	1	1	0	0
5° 46' – 9° 52'	5	5	4	4	3	3	2	2	1	1	0
9° 52' – 12° 44'	6	5	5	4	4	3	3	2	2	1	1
12° 44' – 15° 6'	6	6	5	5	4	4	3	3	2	2	1
15° 6' – 17° 10'	7	6	6	5	5	4	4	3	3	2	2
17° 10' – 19° 2'	7	7	6	6	5	5	4	4	3	3	2
19° 2' – 20° 45'	8	7	7	6	6	5	5	4	4	3	3
20° 45' – 22° 22'	8	8	7	7	6	6	5	5	4	4	3
22° 22' – 23° 54'	9	8	8	7	7	6	6	5	5	4	4
23° 54' – 25° 21'	9	9	8	8	7	7	6	6	5	5	4
25° 21' – 26° 45'	10	9	9	8	8	7	7	6	6	5	5
26° 45' – 28° 6'	10	10	9	9	8	8	7	7	6	6	5
28° 6' – 29° 25'	11	10	10	9	9	8	8	7	7	6	6
29° 25' – 30° 41'	11	11	10	10	9	9	8	8	7	7	6
30° 41' – 31° 56'	12	11	11	10	10	9	9	8	8	7	7
31° 56' – 33° 9'	12	12	11	11	10	10	9	9	8	8	7
33° 9' – 34° 21'	13	12	12	11	11	10	10	9	9	8	8
34° 21' – 35° 31'	13	13	12	12	11	11	10	10	9	9	8
35° 31' – 36° 41'	14	13	13	12	12	11	11	10	10	9	9
36° 41' – 37° 50'	14	14	13	13	12	12	11	11	10	10	9
37° 50' – 38° 58'	15	14	14	13	13	12	12	11	11	10	10
38° 58' – 40° 5'	15	15	14	14	13	13	12	12	11	11	10
40° 5' – 41° 12'	16	15	15	14	14	13	13	12	12	11	11
41° 12' – 42° 19'	16	16	15	15	14	14	13	13	12	12	11
42° 19' – 43° 26'	17	16	16	15	15	14	14	13	13	12	12
43° 26' – 44° 32'	17	17	16	16	15	15	14	14	13	13	12
44° 32' – 45° 38'	18	17	17	16	16	15	15	14	14	13	13
45° 38' – 46° 45'	18	18	17	17	16	16	15	15	14	14	13
46° 45' – 47° 51'	19	18	18	17	17	16	16	15	15	14	14
47° 51' – 48° 58'	19	19	18	18	17	17	16	16	15	15	14
48° 58' – 50° 6'	20	19	19	18	18	17	17	16	16	15	15
50° 6' – 51° 13'	20	20	19	19	18	18	17	17	16	16	15
51° 13' – 52° 22'	21	20	20	19	19	18	18	17	17	16	16
52° 22' – 53° 31'	21	21	20	20	19	19	18	18	17	17	16
53° 31' – 54° 41'	22	21	21	20	20	19	19	18	18	17	17
54° 41' – 55° 52'	22	22	21	21	20	20	19	19	18	18	17
55° 52' – 57° 4'	23	22	22	21	21	20	20	19	19	18	18
57° 4' – 58° 17'	23	23	22	22	21	21	20	20	19	19	18
58° 17' – 59° 32'	24	23	23	22	22	21	21	20	20	19	19
59° 32' – 60° 49'	24	24	23	23	22	22	21	21	20	20	19
60° 49' – 62° 9'	25	24	24	23	23	22	22	21	21	20	20
62° 9' – 63° 30'	25	25	24	24	23	23	22	22	21	21	20
63° 30' – 64° 55'	26	25	25	24	24	23	23	22	22	21	21
64° 55' – 66° 24'	26	26	25	25	24	24	23	23	22	22	21
66° 24' – 67° 57'	27	26	26	25	25	24	24	23	23	22	22
67° 57' – 69° 35'	27	27	26	26	25	25	24	24	23	23	22
69° 35' – 71° 21'	28	27	27	26	26	25	25	24	24	23	23
71° 21' – 73° 16'	28	28	27	27	26	26	25	25	24	24	23
73° 16' – 75° 24'	29	28	28	27	27	26	26	25	25	24	24
75° 24' – 77° 52'	29	29	28	28	27	27	26	26	25	25	24
77° 52' – 80° 56'	30	29	29	28	28	27	27	26	26	25	25
80° 56' – 85° 45'	30	30	29	29	28	28	27	27	26	26	25
85° 45' – 90° 00'	31	30	30	29	29	28	28	27	27	26	26